

Made
in Italy

—

Prodotto
in Italia











—

Fabriqué
en Italie

—

Fabricado
en Italia

PROMO 77

F1 – C CR	118	Technical information	193	Technical information	249
F1T – GOM C CR	120	informazioni tecniche		informazioni tecniche	
F1T – GOM CB CR	122				
F1T – GOM 30 CR	124				
Technical information	126				
informazioni tecniche					
<hr/>					
Dot	128	Tag	194	Bay	250
retractable / meccanismo a scatto		twist-action / meccanismo a rotazione		twist-action / meccanismo a rotazione	
D1 – MATT B	130	TA1 – MATT AL B	196	B500 – MATT BC	252
D1 – MATT CB	132	TA1 – B CR	198	B500 – MATT	254
D1 – MATT	134	TA1 – C CR	200	B500 – BC	256
D1 – MATT K	136			B500 – C	257
D1 – MATT F	138	Technical information	203	B500 – 30	258
D1 – B CR	140	informazioni tecniche		B500 – FROST	259
D1 – CB CR	142			B500 – MATT RE 	260
D1 – C CR	144			B500 – C AB 	262
D1 – 30 CR	146				
D1 – GOM K	148	Icon	204	Technical information	265
D1 – GOM CB CR	150	twist-action / meccanismo a rotazione		informazioni tecniche	
D1 – GOM C CR	152	IC400 – MATT AL	206		
D1 – GOM 30 CR	154	IC400 – C CR	208		
D1 – C GOLD	156	IC400 – 30 CR	210	More about Maxema	266
D1 – GOM KF CR	157	IC400 – C GOLD	212	Scopri di più su Maxema	
D1 – MATT CB RE 	158	IC400 – AL CR	213		
D1 – MATT RE 	160	Technical information	215	Fast and reliable	270
D1 – MATT CB AB 	162	informazioni tecniche		Veloci e affidabili	
Technical information	165			Pens customisation	272
informazioni tecniche				Personalizzazione penne	
<hr/>					
Zink	166	Ethic	216	Cases	280
twist-action / meccanismo a rotazione		twist-action / meccanismo a rotazione		Astucci	
Z1 – CB	168	ET900 – MULTICOLOUR	218	Cases customisation	290
Z1 – C	170	ET900 – FLAG	219	Astucci su misura	
Z1 – 30	172	ET900 – C FLAG	219		
Z1 – CF	174	ET900 – B	220	Sample sets	292
Z1 – CB RE 	176	ET900 – BC	221	Campionari	
Z1 – C RE 	178	ET900 – C CR	222		
Z1 – C AB 	180	ET900 – C GOLD	223		
Technical information	183	Technical information	225	Colour palette	304
informazioni tecniche		informazioni tecniche		Palette colori	
<hr/>					
View	184	Pixel	226	Inks and refills	306
twist-action / meccanismo a rotazione		retractable / meccanismo a scatto		Inchiostri e refill	
V1 – C CR / V1 – C CR T	186	PX40 – MATT CB	228		
V1 – 30 CR / V1 – 30 CR T	188	PX40 – MATT	230		
V1 – AL CR / V1 – AL CR T	189	PX40 – MATT CR	232		
V1 – GOM C CR /	190	PX40 – B	234		
V1 – GOM C CR T	190	PX40 – C	235		
		PX40 – 30	236		
		PX40 – FROST NEUTRAL	237		
		PX40 – FROST	238		
		PX40 – GOM C CR	240		
		PX40 – GOM 30 CR	241		
		PX40 – MATT CB RE 	242	Download the PDF version	
		PX40 – MATT RE 	244	Scarica la versione PDF	
		PX40 – MATT CB AB 	246	→	



Quality, not quantity.

This attitude has guided our journey every step along the way for over thirty years. Driven by our responsibility and the unrelenting desire to improve, we seek quality through innovation, creating writing instruments capable of conveying sustainable ideas and messages, able to leave a lasting mark.

Qualità, non quantità. Questa è l'attitudine che, da oltre trent'anni, guida il nostro percorso e definisce i nostri passi. Mossi dalla responsabilità e dalla voglia di migliorarci costantemente, ricerchiamo la qualità attraverso l'innovazione, per creare strumenti di scrittura capaci di diventare portatori di idee e messaggi sostenibili, in grado di lasciare un segno duraturo.

Every choice we make outlines the future.

Ogni scelta che facciamo delinea il futuro.



Every Maxema pen is made in Italy and is the outcome of extensive research and a production process that focuses on detail. **We choose safe, non-toxic materials**, favouring Italian and European suppliers to guarantee durable and reliable products. For us, a pen is not just an instrument. It is a medium for stories, commitment and values. We believe that even a pen can help us write a better tomorrow.

That's why our collection includes product lines made from recycled raw materials such as **post-consumer ABS plastic, R-PET** and **post-industrial recycled (PIR) ABS plastic**. We have also always recovered and reused scraps from plastic processing.

Our commitment to sustainability has led us to work with partners who share our goals, such as **Oceanworks, ClimatePartner, Alperia** and **Plastic Bank**, all trusted organisations that guarantee a transparent, certified supply chain for their products and services.

Ogni penna Maxema è realizzata in Italia ed è frutto di una lunga ricerca e di un processo produttivo curato in ogni dettaglio. **Scegliamo materiali sicuri e atossici, privilegiando fornitori italiani ed europei, per garantire prodotti durevoli e affidabili**. Per noi, una penna non è solo uno strumento. È veicolo di storie, impegno e valori. Crediamo che, anche attraverso una penna, si possa contribuire a scrivere un domani migliore. Per questo abbiamo inserito nella nostra collezione linee prodotte con materie prime riciclate come la plastica **ABS Post Consumo**, l'**R-PET** e la plastica **ABS PIR (Post-Industrial Recycled)** e da sempre recuperiamo e riutilizziamo gli sfridi di lavorazione della plastica.

Il nostro impegno per una produzione più sostenibile ci ha portato a selezionare partner che condividono i nostri stessi obiettivi come **Oceanworks, ClimatePartner, Alperia** e **Plastic Bank**, realtà affidabili che garantiscono una filiera trasparente e certificata per i loro prodotti e servizi.

Tomorrow is like a blank sheet of paper ready to be filled with our ideas and goals.

Our commitment to protecting the environment is an invitation to act together: we want to inspire companies and individuals to write a better future and choose products that respect the planet and people. Because only by sharing visions and responsibilities can we really write a beautiful story. A story that will stand the test of time.

Il domani è come un foglio bianco, pronto ad essere riempito con le nostre idee e i nostri obiettivi. Il nostro impegno a tutela dell'ambiente è un invito ad agire insieme: vogliamo ispirare aziende e persone a scrivere un futuro migliore e scegliere prodotti che rispettino il pianeta e le persone. Perché solo condividendo visioni e responsabilità possiamo davvero scrivere una bella storia. Una storia capace di durare nel tempo.

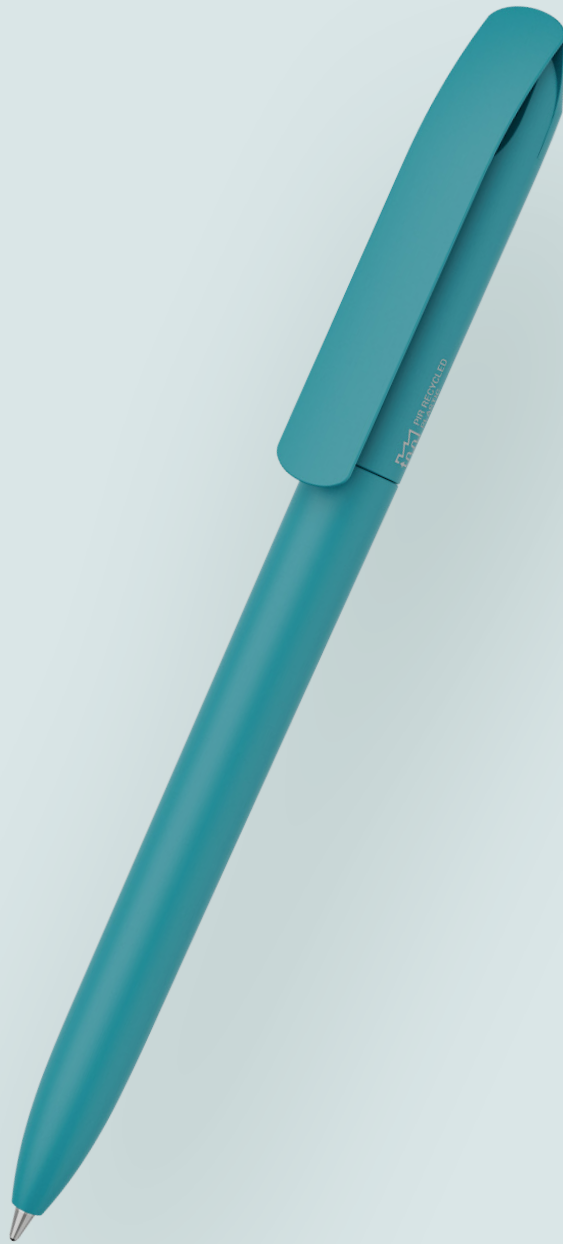

We use only energy from renewable sources

Usiamo solo energia da fonti rinnovabili.



EN

Change starts with our choices.
In cooperation with the Alperia Group,
we only use energy from renewable sources, namely hydroelectric power stations in South Tyrol.

IT

Il cambiamento inizia dalle nostre scelte.
In collaborazione con Alperia Group, **usiamo solo energia proveniente da fonti rinnovabili**, per la precisione da centrali idroelettriche dell'Alto Adige.





We want to reduce our carbon footprint.

Vogliamo ridurre la nostra impronta di carbonio.



ClimatePartner
certified company
climate-id.com/94EEJU



plasticbank®



EN

Our company is ClimatePartner certified.

To deliver our commitment in transparent fashion, we have calculated Maxema's corporate carbon footprint and defined new targets and ways to help reduce it. We know, however, that there will always be emissions that we cannot avoid or reduce. To offset these, we have chosen to fund a climate protection initiative in association with the **Plastic Bank** project, an organisation that provides a stable income for groups of people who commit to removing plastic from coast-lines and oceans. The material collected is then turned into raw material for re-use in other products and packaging, so contributing to the circular economy.

IT

La nostra azienda è certificata ClimatePartner.

Per comunicare in modo trasparente il nostro impegno abbiamo calcolato l'impronta di carbonio aziendale di Maxema e definito nuovi obiettivi e modalità per contribuire a ridurla. Sappiamo, però, che ci saranno sempre delle emissioni che non potremo evitare o diminuire. Per compensarle, abbiamo scelto di sostenere finanziariamente un'iniziativa di protezione del clima abbinato al progetto **Plastic Bank**, un'organizzazione che permette un reddito stabile a gruppi di persone che si impegnano ad eliminare la plastica dalle coste e dagli oceani. Il materiale raccolto viene poi trasformato in materia prima per essere riutilizzato in altri prodotti e imballaggi, contribuendo all'economia circolare.



Tante penne, infinite storie. Scrivi la tua.

**Many pens,
endless stories.**

Write yours.

Zed



PIR RECYCLED
PLASTIC

Restart from the end. Restart from Zed.
Riparti dalla fine. Riparti da Zed.

Sharp design,
circular message.

*Design affilato,
messaggio circolare.*

**Download Post-Industrial
Recycled ABS Catalogue**

→

Scarica il catalogo Post-Industrial
Recycled ABS



Technical information at p. 29
Informazioni tecniche a pag. 29

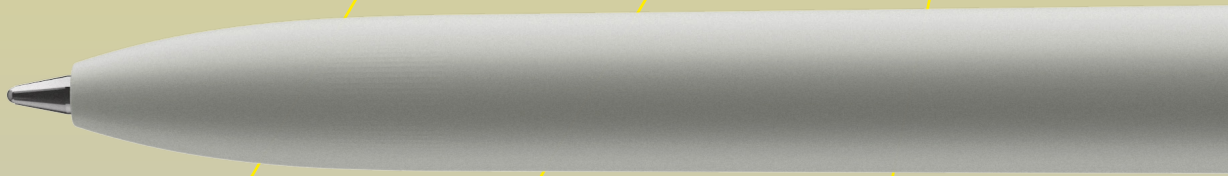

Last letter. Design first.



EN

An understated design with a bold profile and unprecedented scope for customisation. Zed is our model made of certified, traceable post-industrial recycled (PIR) ABS plastic. A pen with a strong character, combining a perfect balance of form and function. Designed to restore value to what remains at the end of the production cycle. Write a new story starting from the end, restart from Zed.

IT

Un design essenziale dal profilo grintoso e uno spazio di personalizzazione senza precedenti. Zed è il nostro modello in plastica ABS riciclata post industriale (PIR), certificata e tracciata. Una penna dal carattere deciso, che unisce forma e funzione in un equilibrio perfetto. Pensata per restituire valore a ciò che resta alla fine del ciclo di produzione. Scrivi una nuova storia partendo dalla fine, inizia da Zed.

PIR plastic: end of waste, start of reuse.

Plastica PIR: fine dello spreco, inizio del riuso.

EN

PIR (Post-Industrial Recycled) ABS plastic is created from the waste generated by the production process: a recycled material obtained from plastics that never reached the market. This material offers excellent performance and a high level of purity, significantly more sustainable than virgin plastic: it reduces energy consumption, limits CO₂ emissions and enhances what already exists.

IT

Dagli sfridi generati durante i processi produttivi, nasce la plastica ABS PIR (Post-Industrial Recycled): un materiale riciclato ottenuto da plastiche che non hanno mai raggiunto il mercato. Questo materiale offre ottime prestazioni e un livello di purezza elevato, notevolmente più sostenibile rispetto alla plastica vergine: riduce i consumi energetici, limita le emissioni di CO₂ e valorizza ciò che esiste già.



Solid colours barrel with matt finish,
solid matt white colour cap.

Brand visibility
enhanced with
the white clip.



03



18



16



15



79



09

23 violet / pad printing 47 x 9 mm
23 viola / tampografia 47 x 9 mm

Z8

MATT CB PIR

Fusto in colore coprente con finitura satinata, cappuccio in colore bianco coprente satinato.

Brand più in evidenza con la clip bianca.

27 octan green / pad printing 47 x 9 mm
27 ottanio / tampografia 47 x 9 mm



75

77

12

05

11

04

22 blue / pad printing 47 x 9 mm
22 blu / tampografia 47 x 9 mm

Solid colours with matt finish.

Designed
to stand out.

16 bright red /
pad printing 47 x 9 mm
16 rosso vivo /
tampografia 47 x 9 mm



01

03

18

15

23

79

09

Z8

MATT PIR

Colori coprenti con finitura satinata.

Progettata
per distinguersi.



75



27



77



12



22



05



11 dark grey /
pad printing 47 x 9 mm
11 grigio scuro /
tampografia 47 x 9 mm



04

Technical information
Informazioni tecniche

Zed Post-Industrial Recycled

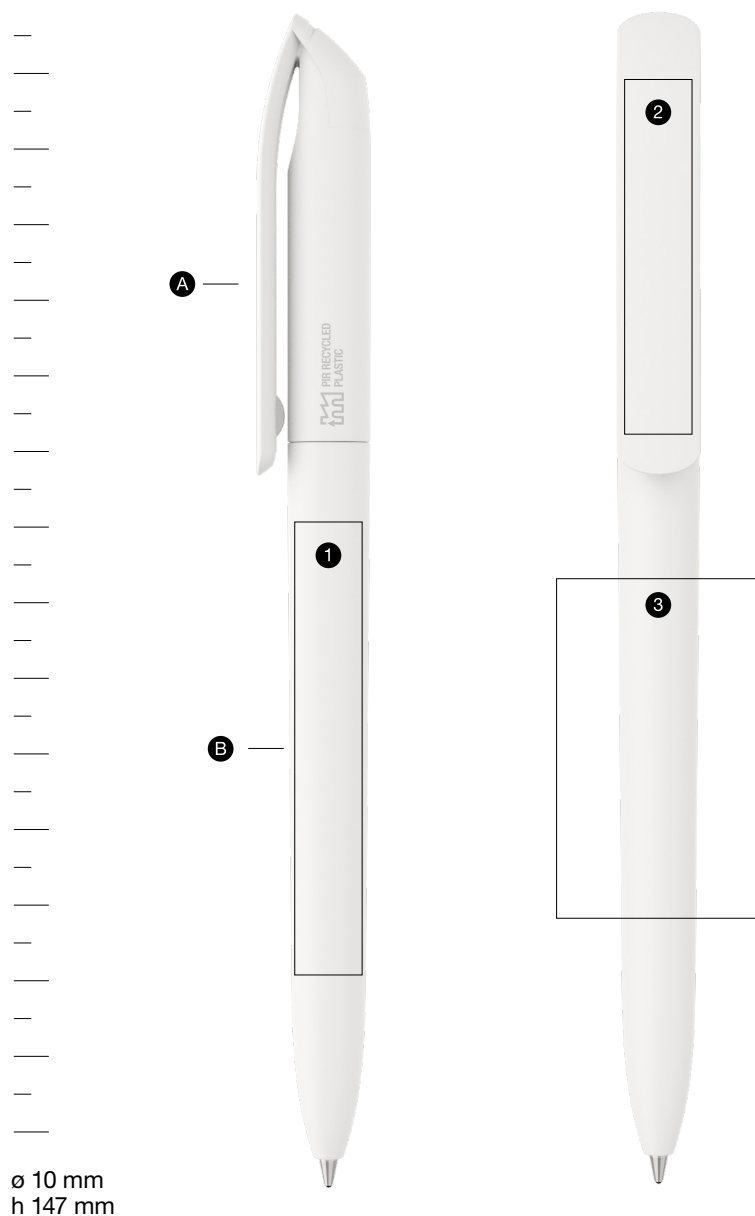

Components / Componenti

- Ⓐ Cap / cappuccio
- Ⓑ Barrel / fusto

Print area / Area stampabile

- ① pad printing / tampografia
60 x 9 mm
- ② pad printing / tampografia
47 x 9 mm
- ③ screen printing / serigrafia
45 x 27 mm

Features / Caratteristiche

twist-action / meccanismo a rotazione

Made from certified and traceable post-industrial recycled ABS plastic (PIR) / Realizzata in plastica ABS riciclata post-industriale (PIR) certificata e tracciata

Made of 90% PIR plastic in the following colours: 01 white, 05 grey, 11 dark grey, 04 black. PIR plastic content is 80% for all other available colours / Prodotta con il 90% di plastica PIR nei seguenti colori: 01 bianco, 05 grigio, 11 grigio scuro, 04 nero. Per tutti gli altri colori disponibili il contenuto di plastica PIR è l'80%

Jumbo refill, blue and black ink / refill Jumbo, inchiostro blu e nero

available in matt finish / disponibile con superfici satinare



Small imperfections and slight colour variations are to be considered intrinsic features of the PIR ABS plastic. / Piccole imperfezioni e lievi variazioni cromatiche sono da considerarsi caratteristiche intrinseche della plastica ABS PIR.

Kind

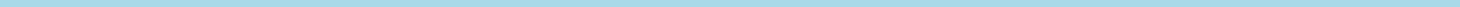
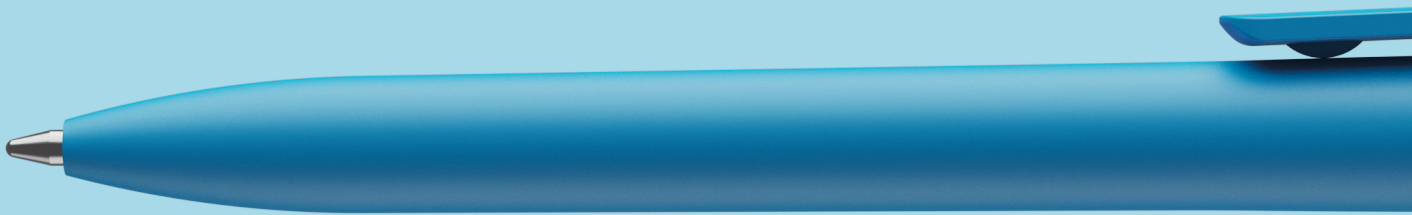

Message from a bottle.
Messaggio da una bottiglia.

Created to
write change.

*Realizzata per scrivere
il cambiamento.*



**Download
R-PET
catalogue**

→

Scarica il catalogo R-PET



Technical information at p. 49
Informazioni tecniche a pag. 49



Maxema chooses OCEANWORKS®

Maxema sceglie OceanWorks®

EN

Less talk, more facts. It is not enough for us to convey sustainable messages, we want to be an active part of a wave of change. That's why we have decided to partner with Oceanworks, a global platform committed to reducing plastic pollution in our oceans. Through a network of collectors and collaborators, it provides recycled and certified materials, guaranteeing transparency and traceability in the supply chain, from the origins of the plastic waste to the final product. Together we have produced the Kind, made of **R-PET plastic sourced exclusively from ocean-bound clean-ups.**

A concrete choice to reduce our environmental footprint and offer you a truly sustainable promotional tool.

IT

Meno parole, più fatti. Non ci basta trasmettere messaggi sostenibili, vogliamo essere parte attiva di un'onda di cambiamento. Per questo abbiamo scelto di collaborare con Oceanworks, una piattaforma globale impegnata a ridurre l'inquinamento da plastica negli oceani. Attraverso una rete di raccoglitori e collaboratori in tutto il mondo, fornisce materiali riciclati e certificati, garantendo trasparenza e tracciabilità nella supply chain, dall'origine dei rifiuti plastici fino alla produzione finale. Insieme abbiamo realizzato Kind, prodotta con materiale plastico **R-PET proveniente esclusivamente da attività di pulizia delle coste oceaniche.** Una scelta concreta per ridurre la nostra impronta ambientale e darti uno strumento promozionale realmente sostenibile.



100% R-PET Pens

Penne in 100% R-PET



EN

The Kind is our pen made from **100% recycled PET**, a material sourced from plastic bottles collected by Oceanworks, a globally active organisation specialising in recycling ocean-bound plastic, with whom we have formed an exclusive partnership.

IT

Kind è la nostra penna in **100% PET riciclato**, un materiale recuperato dalle bottiglie di plastica raccolte lungo le coste oceaniche da Oceanworks, un'organizzazione attiva a livello mondiale per promuovere soluzioni circolari per la plastica, con la quale abbiamo stretto una partnership esclusiva.

**Scan the
QR Code
and Be Kind.**

Scannerizza
il QR code
e Be Kind.



R-PET reduces emissions

Il materiale R-PET riduce le emissioni

EN

R-PET helps reduce environmental impact: studies have found that its use **saves 50% of CO₂ compared to virgin PET.**

IT

Il materiale R-PET contribuisce a ridurre l'impatto ambientale: secondo gli studi, il suo utilizzo **consente di risparmiare il 50% di CO₂ rispetto all'uso di PET vergine.**

Source/Fonte: Oceanworks



Download
R-PET
catalogue



Scarica il
catalogo R-PET





K1 MATT CB RP

Solid colour barrel with matt finish,
solid matt white colour clip
and push-button

White clip: ideal
for multicolour
brands.

18 orange / pad printing
32 x 7 mm
18 arancio / tampografia
32 x 7 mm



03



15



79



09 green / pad printing 32 x 7 mm
09 verde / tampografia 32 x 7 mm

K1 | MATT CB RP

Fusto in colore coprente con finitura satinata, clip e tappino in colore bianco coprente satinato

Clip bianca:
ideale per i brand
a più colori.



75



77



12



22 blue / pad printing 32 x 7 mm
22 blu / tampografia 32 x 7 mm



05



04

15 red / pad printing 32 x 7 mm
15 rosso / tampografia 32 x 7 mm

Strong visual
impact, low
environmental
impact.



03



18



79



09

01 white / pad printing 32 x 7 mm
01 bianco / tampografia 32 x 7 mm

K1 | MATT RP

Colori coprenti con finitura satinata

Alto impatto
visivo, basso
impatto
ambientale.



77

12

22

05

04

75 dark green / pad printing 32 x 7 mm
75 verde scuro / tampografia 32 x 7 mm

K1 | GOM MATT CB RP

Solid colour barrel with rubber finish, solid white colour clip and push button

Soft touch,
safe grip.



03



18



15



09

79 lime / pad printing 32 x 7 mm
tampografia 32 x 7 mm

Extra customisation is available to tell the story of this pen's origin. Info at page 268

Disponibile una personalizzazione extra per raccontare l'origine di questa penna. Info a pag. 268

K1 | GOM MATT CB RP

*Fusto in colore coprente gommato,
clip e tappino in colore bianco
coprente satinato*

Morbida al tatto,
grip perfetto.

77 cyan / pad printing 32 x 7 mm
77 ciano / tampografia 32 x 7 mm



75



12



22



05



04 black / pad printing 32 x 7 mm
04 nero / tampografia 32 x 7 mm

K1 | GOM MATT RP

18 orange / pad printing 32 x 7 mm
 18 arancio / tampografia 32 x 7 mm

Solid colour barrel with rubber finish, solid colour clip and push button with matt finish

Per Kind è disponibile l'astuccio My Case dedicato. Scoprilò a pag. 276.



01



03



15



79



09 green / pad printing 32 x 7 mm
 09 verde / tampografia 32 x 7 mm

K1 | GOM MATT RP

*Fusto in colore coprente gommato,
tappino e clip in colore coprente
satinato*

The dedicated My
Case pen box is
available for the
Kind. Learn more
on page 276.



75



77



22



05



04

12 light blue / pad printing 32 x 7 mm
12 azzurro / tampografia 32 x 7 mm

K1 | FROST RP

Transparent colours
with matt finish

Transparent
is cool!



39



53



45

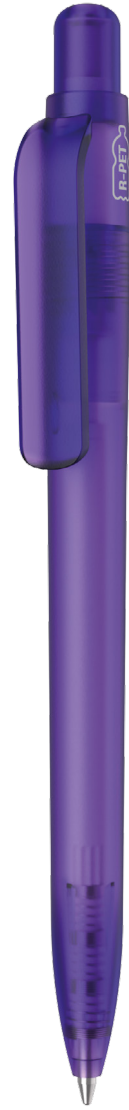

55

52 yellow / pad printing 32 x 7 mm
52 giallo / tampografia 32 x 7 mm

K1 | FROST RP

*Colori trasparenti
con finitura satinata***Trasparente
è cool!**49 green / pad printing 32 x 7 mm
49 verde / tampografia 32 x 7 mm

78



67



44



32

50 dark grey / pad printing 32 x 7 mm
50 grigio scuro / tampografia 32 x 7 mm

Technical information
Informazioni tecniche

Kind R-PET

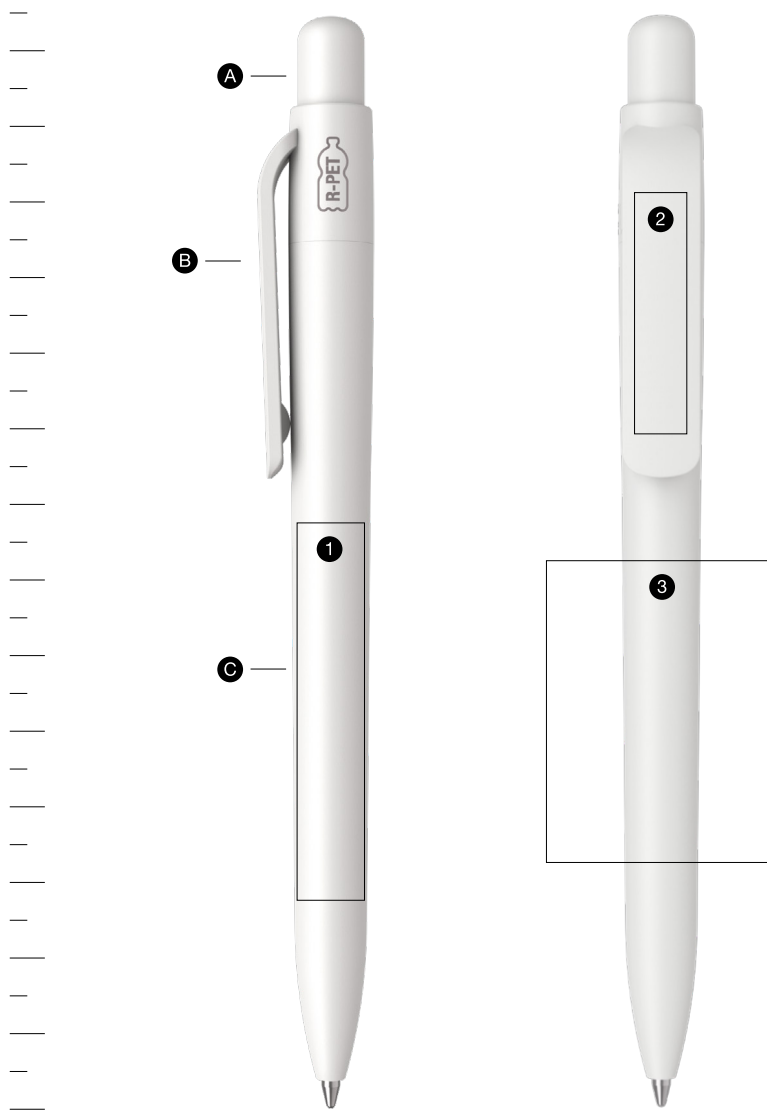

ø 10 mm
h 141,5 mm

Components / Componenti

- Ⓐ Push-button / *tappino*
- Ⓑ Clip
- Ⓒ Barrel / *fusto*

Print area / Area stampabile

- ① pad printing / *tampografia*
50 x 9 mm
- ② pad printing / *tampografia*
32 x 7 mm
- ③ screen printing / *serigrafia*
40 x 30 mm

Features / Caratteristiche

retractable /
meccanismo a scatto

Made of certified R-PET collected
from ocean-bound regions / *realizzata*
in R-PET certificato, raccolto dalle
zone costiere oceaniche

Jumbo refill, blue and black ink
/ refill Jumbo, inchiostro blu e nero

the barrel is available in matt and
rubber finishes, the clip and the push-
button are available in matt finish
/ il fusto è disponibile con superfici
satinate e gommate, la clip e il tappino
sono disponibili con superfici satinate



R-PET PLASTIC / *PLASTICA R-PET*

Small imperfections and slight colour variations
are to be considered intrinsic features of the
reuse of recycled PET material. /

Piccole imperfezioni e lievi variazioni cromatiche
sono da considerarsi caratteristiche intrinseche
del riutilizzo del materiale PET riciclato.

Mood Metal



Design with a metal touch.
Il design incontra il metallo.

Luxury is a state of mind.
Il lusso è un'attitudine.

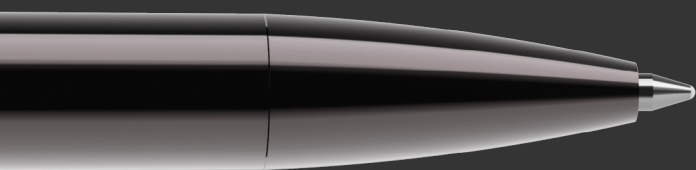

Technical information at p. 59
Informazioni tecniche a pag. 59

MD1 | M M1

Chrome finish metal barrel, tip and push-button, solid colour clip with glossy finish, solid glossy colour little sphere

Metal details with diamond mirror finish.



01 70 03 18 15

60 61 71 25 72 73

74 burgundy / pad printing 40 x 9 mm
74 bordeaux / tampografia 40 x 9 mm

All Mood models come with a single My Box case in Fedrigoni Ardesia recycled cardboard included. Info at p. 288

Tutti i modelli Mood vengono forniti con astuccio singolo My Box in cartoncino riciclato Fedrigoni Ardesia incluso. Info pag. 288

Fusto, punta e tappino in metallo con finitura cromata, clip in colore coprente lucido, piccola sfera in colore coprente lucido

Finitura
a specchio
diamantata per
i particolari
in metallo.

75 dark green / pad printing 40 x 9 mm
75 verde scuro / tampografia 40 x 9 mm

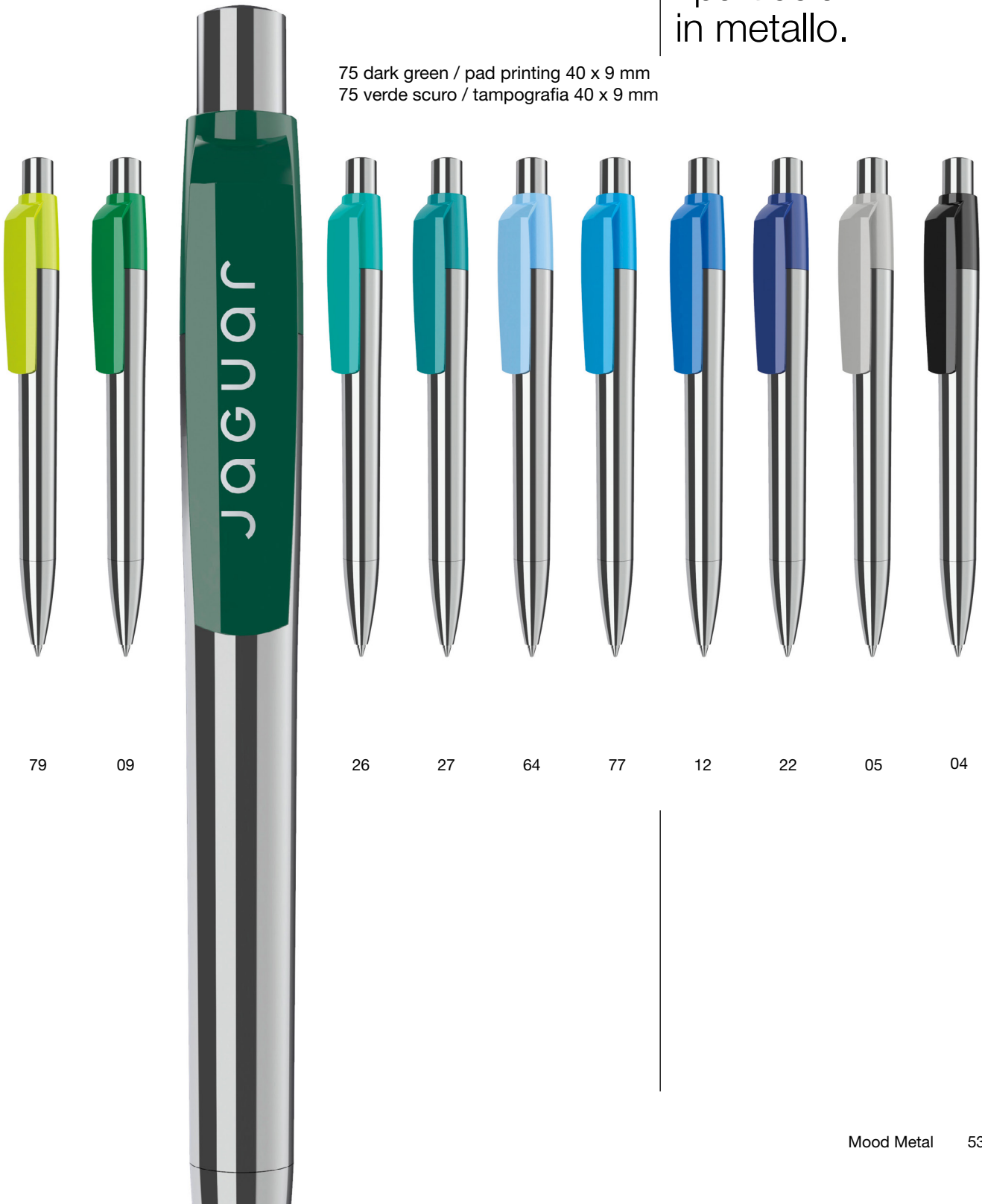

79

09

26

27

64

77

12

22

05

04

MD1 | M M4

Titanium grey finish metal barrel, tip and push-button, solid colour clip with glossy finish, solid glossy colour little sphere

Titanium grey finish: metal in a dynamic version.



70

03

18

15

74

60

71

72

01 white / pad printing 40 x 9 mm
01 bianco / tampografia 40 x 9 mm

All Mood models come with a single My Box case in Fedrigoni Ardesia recycled cardboard included.
Info at p. 288

*Tutti i modelli Mood vengono forniti con astuccio singolo My Box in cartoncino riciclato Fedrigoni Ardesia incluso.
Info pag. 288*

*Fusto, punta e tappino in metallo con
finitura grigio titanio, clip in colore
coprente lucido piccola sfera in colore
coprente lucido*

Finitura grigio
titanio: il metallo
in versione
dinamica.

04 black / pad printing 40 x 9 mm
04 nero / tampografia 40 x 9 mm



73

79

09

75

27

77

22

05

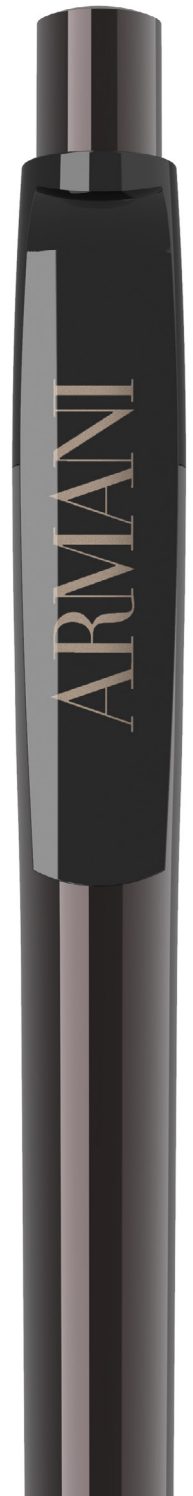

MD1 | M M2

01 white / pad printing 40 x 9 mm
01 bianco / tampografia 40 x 9 mm



Gold finish metal barrel, tip and push-button, solid colour clip with glossy finish, solid glossy colour little sphere

Metal with gold finish: pure light.

All Mood models come with a single My Box case in Fedrigoni Ardesia recycled cardboard included. Info at p. 288

Tutti i modelli Mood vengono forniti con astuccio singolo My Box in cartoncino riciclato Fedrigoni Ardesia incluso. Info pag. 288



Fusto, punta e tappino in metallo con finitura dorata, clip in colore coprente lucido, piccola sfera in colore coprente lucido

Metallo con
finitura oro: luce
allo stato puro.

04 black / pad printing 40 x 9 mm
04 nero / tampografia 40 x 9 mm

Technical information
Informazioni tecniche

Mood Metal

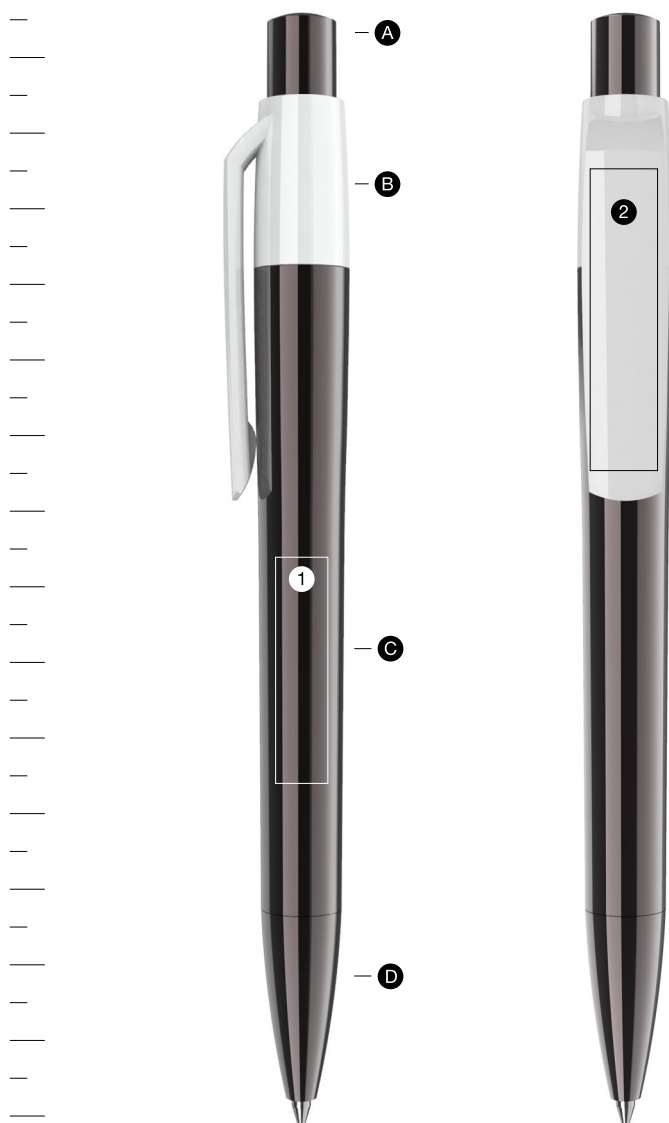

ø 11,5 mm
h 141,5 mm



The entire Maxema collection is available
in post-consumer recycled plastic on request /
*Tutta la collezione Maxema è realizzabile
in plastica riciclata post-consumo su richiesta*

Components / Componenti

- Ⓐ Push-button / tappino
- Ⓑ Clip
- Ⓒ Barrel / fusto
- Ⓓ Tip / punta

Print area / Area stampabile

- ① laser engraving 30 x 7 mm
incisione laser 30 x 7 mm
- ② pad printing / tampografia
40 x 9 mm

Features / Caratteristiche

retractable with return spring /
meccanismo a scatto, con molla
di ritorno

metal push-button, barrel and tip,
individually processed with diamond
mirror face finish / tappino, fusto e
punta in metallo, lavorati singolarmente
con finitura a specchio diamantata

clip made of non-toxic, highly resistant
ABS plastic / clip realizzata in plastica
ABS atossica e ad alta resistenza

“Parker type” refill, blue and black ink /
refill “tipo Parker”, inchiostro blu e nero

Fast Dry Gel blue and black ink available
on request /
*Refill Gel Fast Dry blu e nero disponibile
su richiesta*

Mood

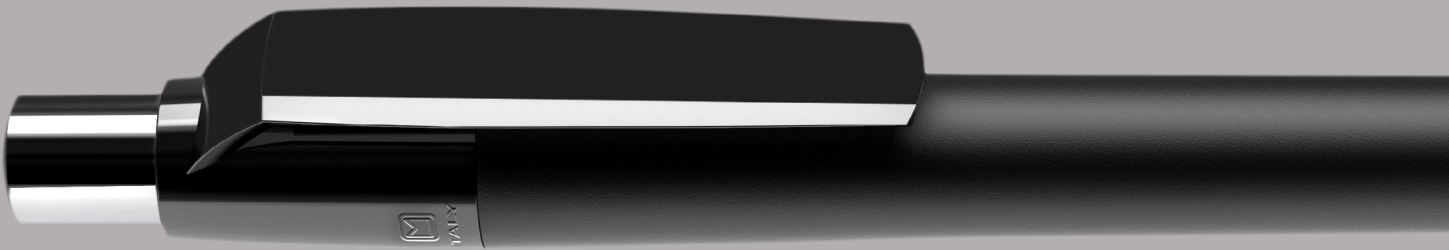

Exclusive and refined.
Esclusiva e raffinata.

Elegance leaves its mark.
L'eleganza lascia il segno.

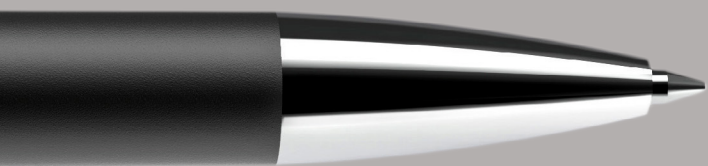

Technical information at p. 73
Informazioni tecniche a pag. 73

MD1 | C M1

Solid colours with glossy finish,
chrome finish metal tip and push-
button, solid glossy colour little sphere



01

70

03

18

15

60

61

71

25

72

74 burgundy / pad printing 40 x 9 mm
74 bordeaux / tampografia 40 x 9 mm

All Mood models come with a single
My Box case in Fedrigoni Ardesia
recycled cardboard included.
Info at p. 288

*Tutti i modelli Mood vengono
forniti con astuccio singolo My Box
in cartoncino riciclato Fedrigoni
Ardesia incluso.
Info pag. 288*

*Colori coprenti con finitura lucida,
punta e tappino in metallo
con finitura cromata, piccola sfera
in colore coprente lucido*



73 79 09 75 26

64 77 12 22 05 04

27 octan green / pad printing 40 x 9 mm
27 ottanio / tampografia 40 x 9 mm

MD1 | GOM CB M1

Solid colour barrel with rubber finish,
solid glossy white colour clip,
chrome finish metal tip and push-
button, solid glossy colour little sphere

18 orange / pad printing 40 x 9 mm
18 arancio / tampografia 40 x 9 mm

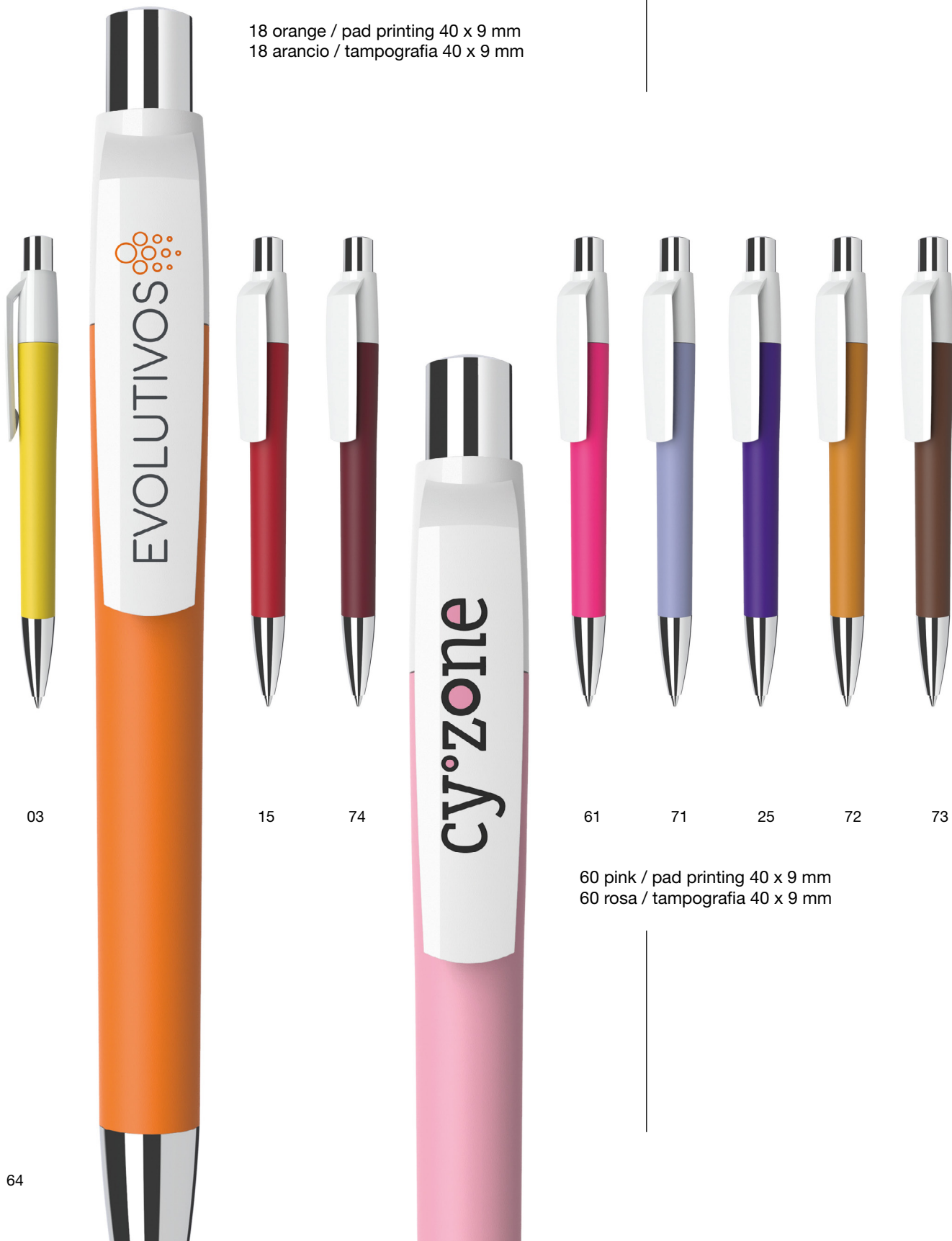

03

15

74

61

71

25

72

73

60 pink / pad printing 40 x 9 mm
60 rosa / tampografia 40 x 9 mm

Fusto in colore coprente gommato, clip in colore bianco lucido, punta e tappino in metallo con finitura cromata, piccola sfera in colore coprente lucido

75 dark green / pad printing 40 x 9 mm
75 verde scuro / tampografia 40 x 9 mm

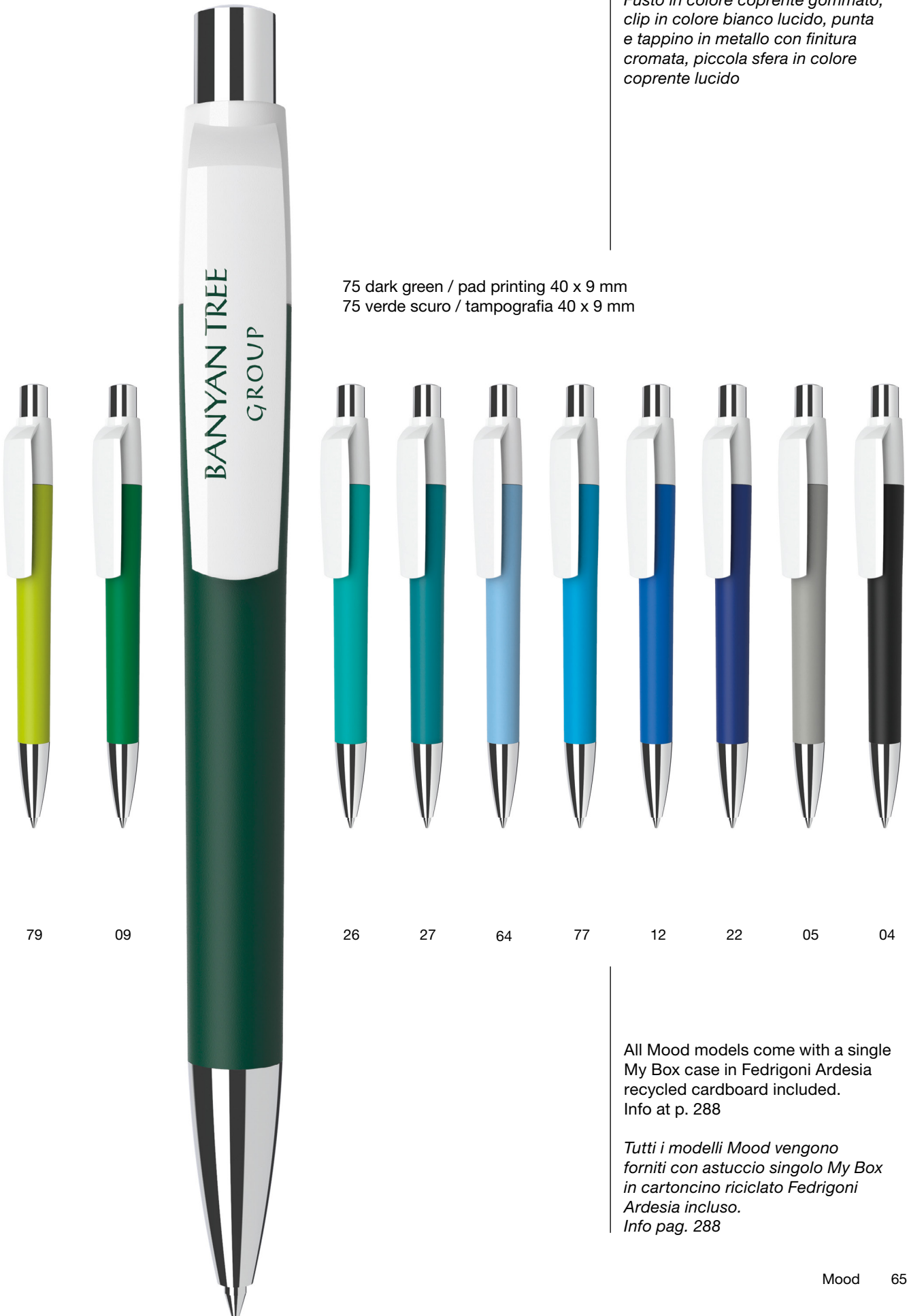

79

09

26

27

64

77

12

22

05

04

All Mood models come with a single My Box case in Fedrigoni Ardesia recycled cardboard included. Info at p. 288

Tutti i modelli Mood vengono forniti con astuccio singolo My Box in cartoncino riciclato Fedrigoni Ardesia incluso. Info pag. 288

MD1 | GOM C M1

Solid colour barrel with rubber finish, solid colour clip with glossy finish, chrome finish metal tip and push-button, solid glossy colour little sphere

Result of superior quality craftsmanship.



70

03

18

15

74

60

61

71

25

72

73

All Mood models come with a single My Box case in Fedrigoni Ardesia recycled cardboard included. Info at p. 288

Tutti i modelli Mood vengono forniti con astuccio singolo My Box in cartoncino riciclato Fedrigoni Ardesia incluso. Info pag. 288

Fusto in colore coprente gommato, clip in colore coprente con finitura lucida, punta e tappino in metallo con finitura cromata, piccola sfera in colore coprente lucido

Risultato
di lavorazioni
artigiane di
qualità superiore.



79

09

75

26

27

64

77

12

22

05

04 black / pad printing 40 x 9 mm
04 nero / tampografia 40 x 9 mm



MD1 | GOM 30 M1

Solid colour barrel with rubber finish, transparent colour clip with glossy finish, chrome finish metal tip and push-button, solid glossy white little sphere

31 light violet / pad printing 40 x 9 mm
31 viola chiaro / tampografia 40 x 9 mm



39

53

45

59

41

55

37

52 yellow / pad printing 40 x 9 mm
52 giallo / tampografia 40 x 9 mm



38

78 lime / pad printing 40 x 9 mm
78 lime / tampografia 40 x 9 mm

Fusto in colore coprente gommato, clip in colore trasparente con finitura lucida, punta e tappino in metallo con finitura cromata, piccola sfera in colore bianco lucido



49

47

34

67

44

30

50

All Mood models come with a single My Box case in Fedrigoni Ardesia recycled cardboard included. Info at p. 288

Tutti i modelli Mood vengono forniti con astuccio singolo My Box in cartoncino riciclato Fedrigoni Ardesia incluso. Info pag. 288



01

04 black / pad printing 40 x 9 mm
04 nero / tampografia 40 x 9 mm



Solid colours with glossy finish, gold finish metal tip and push-button, solid glossy colour little sphere

Colori coprenti con finitura lucida, punta e tappino in metallo con finitura dorata, piccola sfera in colore coprente lucido



All Mood models come with a single My Box case in Fedrigoni Ardesia recycled cardboard included. Info at p. 288

Tutti i modelli Mood vengono forniti con astuccio singolo My Box in cartoncino riciclato Fedrigoni Ardesia incluso. Info pag. 288

MD1 | C M3



01

04 black / pad printing 40 x 9 mm
04 nero / tampografia 40 x 9 mm



Solid colours with glossy finish, rose gold metal tip and push button, solid glossy colour little sphere

Colori coprenti con finitura lucida, punta e tappino in metallo con finitura oro rosa, piccola sfera in colore coprente lucido

Rose gold,
a touch of class
and uniqueness.

Oro rosa,
un tocco di
classe e unicità.

Technical information
Informazioni tecniche

Mood

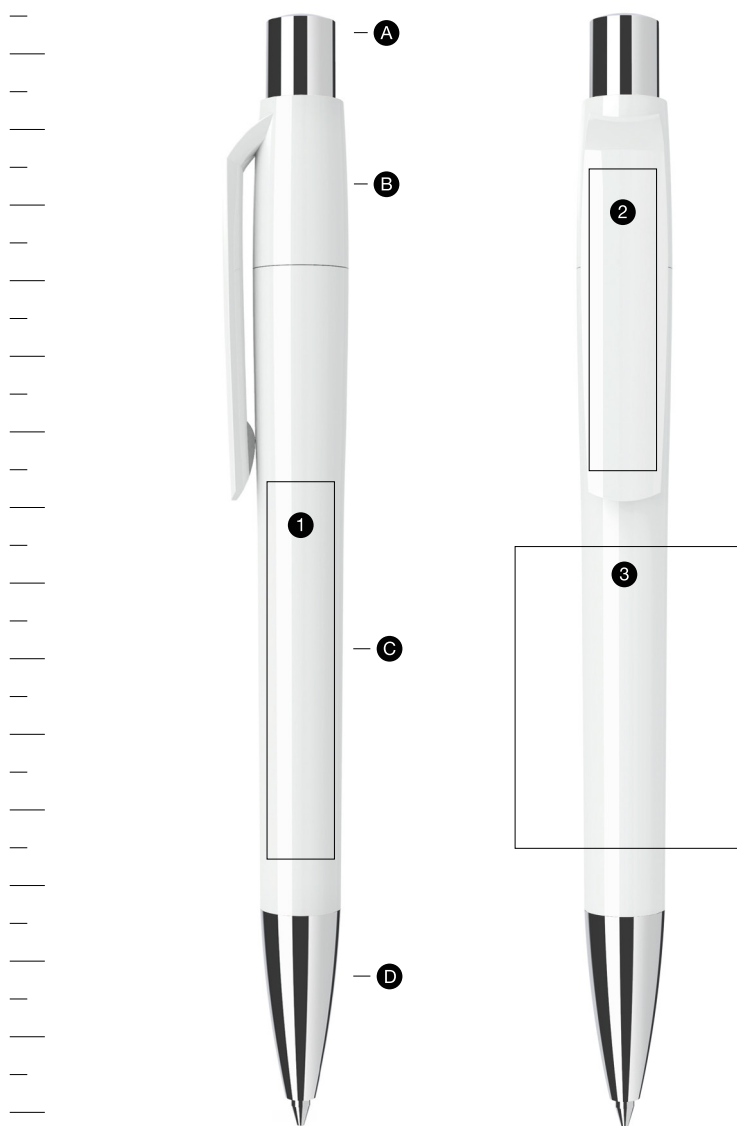

ø 11,5 mm
h 141 mm



The entire Maxema collection is available
in post-consumer recycled plastic on request /
*Tutta la collezione Maxema è realizzabile
in plastica riciclata post-consumo su richiesta*

Components / Componenti

- Ⓐ Push-button / tappino
- Ⓑ Clip
- Ⓒ Barrel / fusto
- Ⓓ Tip / punta

Print area / Area stampabile

- ① pad printing / tampografia
46 x 9 mm
- ② pad printing / tampografia
40 x 9 mm
- ③ screen printing / serigrafia
40 x 30 mm

Features / Caratteristiche

retractable with return spring /
meccanismo a scatto, con molla
di ritorno

made of non-toxic, highly resistant
ABS plastic / realizzata in plastica ABS
atossica e ad alta resistenza

metal tip and push-button,
individually processed with diamond
mirror face finish / tappino e punta in
metallo, lavorati singolarmente con
finitura a specchio diamantata

“Parker type” refill, blue and black ink /
refill “tipo Parker”, inchiostro blu e nero

available in glossy or rubberised finish /
disponibile con superfici lucide
o gommate

Fast Dry Gel blue and black ink available
on request /
*Refill Gel Fast Dry blu e nero disponibile
su richiesta*

Icon Pure



The purity of simplicity.
La purezza della semplicità.

All-round personality.
Personalità a tutto tondo.



Also available in post-consumer recycled plastic /
Disponibile anche in plastica riciclata post-consumo

Technical information at p. 83
Informazioni tecniche a pag. 83

IC8 | MATT

Solid colours with matt finish

NEW



01

70

03

18

15

74

60

61

71

25

72

73

Colori coprenti con finitura satinata

NEW

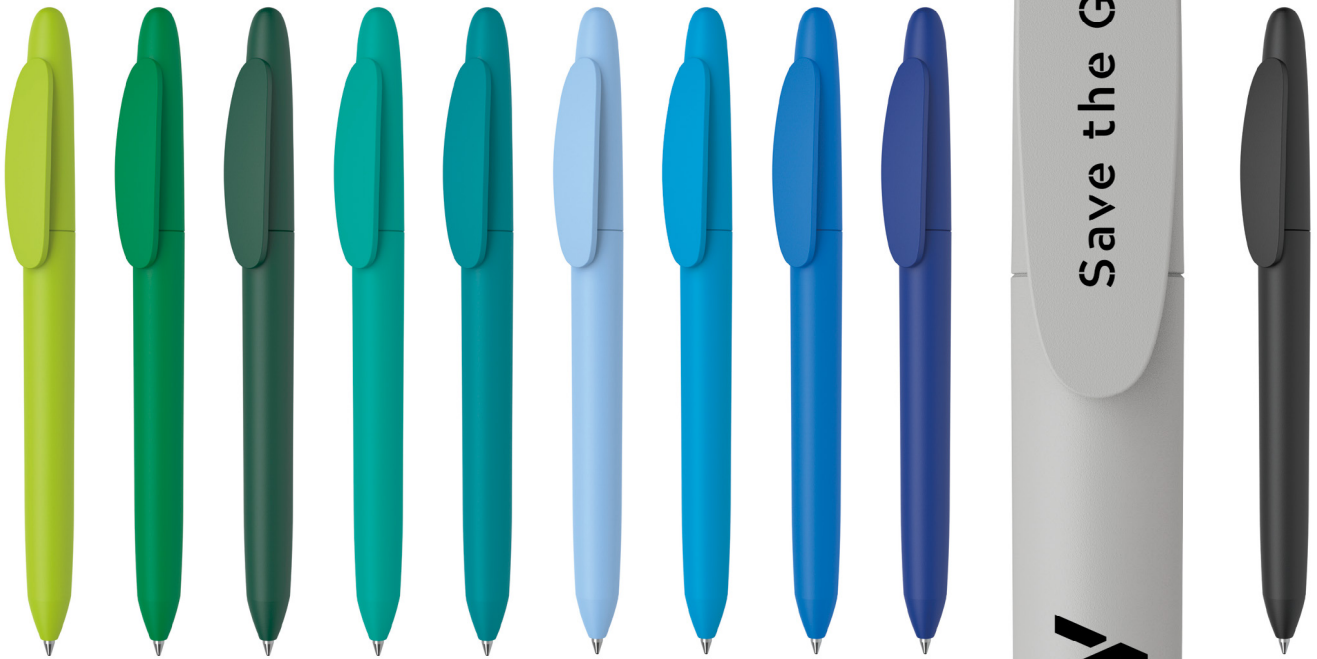

79

09

75

26

27

64

77

12

22

04

05 grey / pad printing 35 x 7 mm
05 grigio / tampografia 35 x 7 mm

SKYYWAY

Full rubber coating on the entire pen: for printing recommendations, please refer to the technical data sheet on page 70.

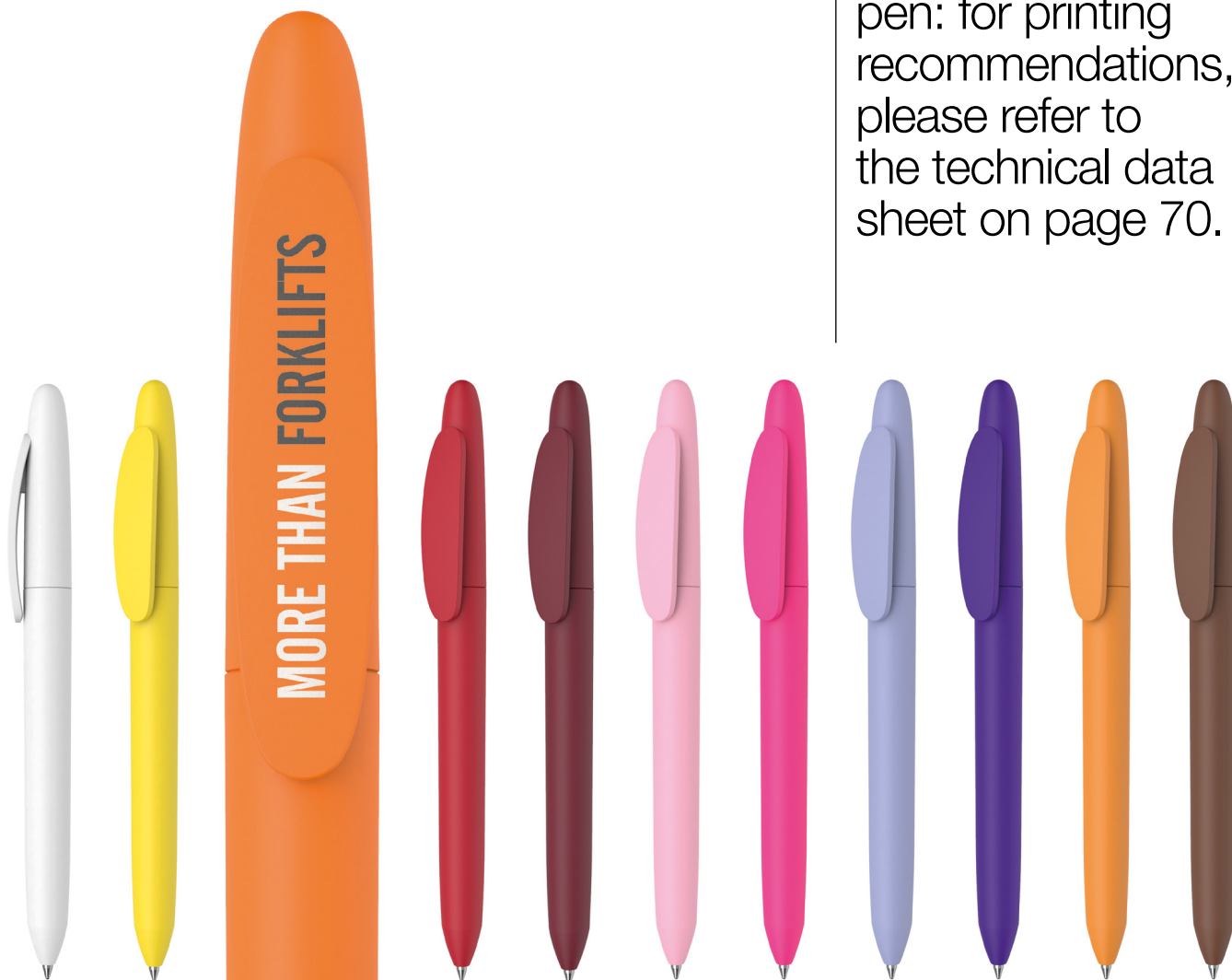

01

03

15

74

60

61

71

25

72

73

18 orange / pad printing 35 x 7 mm
18 arancio / tampografia 35 x 7 mm

Colori coprenti con finitura gommata

Gommatura
integrale su tutta
la penna: per i
consigli di stampa
consultare la
scheda tecnica
a pagina 70.

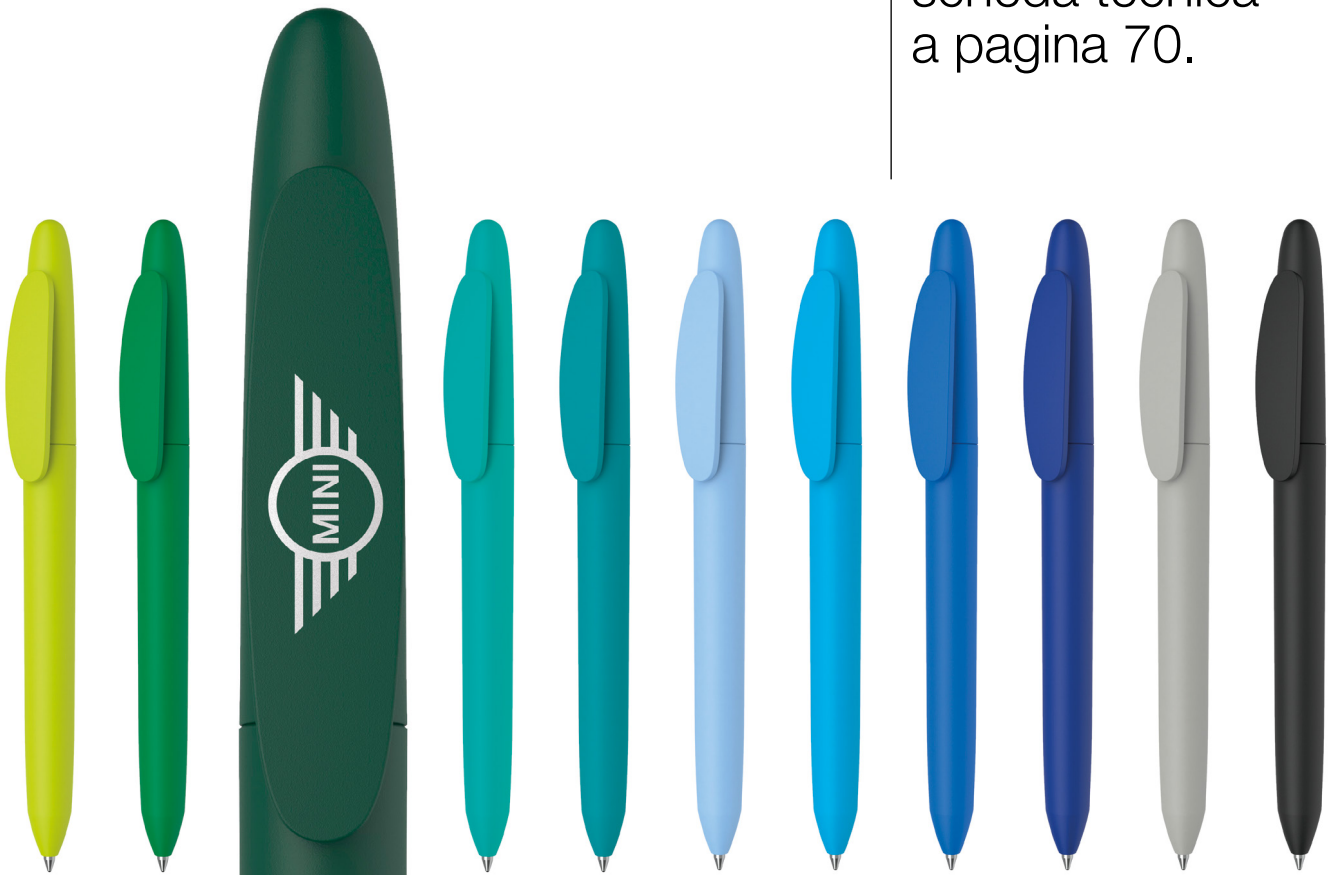

79

09

26

27

64

77

12

22

05

04

75 dark green / pad printing 35 x 7 mm
75 verde scuro / tampografia 35 x 7 mm



IC8 | MATT RE

RECYCLED PLASTIC POST-CONSUMER RECYCLED PLASTIC

Post-consumer recycled plastic
Solid colours with matt finish

Made of WEEE
(Waste of Electrical
and Electronic
Equipment)
recycled plastic.



06



10



76



87 mud / pad printing 35 x 7 mm
tampografia 35 x 7 mm



Universal reclosable single pen case
in Fedrigoni recycled paper Ardesia.
Info at p. 288

*Astuccio universale richiudibile per
penna singola in cartoncino riciclato
Fedrigoni Ardesia.
Info pag. 288*



*Plastica riciclata post-consumo
Colori coprenti con finitura satinata*

Realizzata in
plastica riciclata
da RAEE (Rifiuti
di Apparecchiature
Elettriche ed
Elettroniche).



19

21

58

07 onyx / pad printing 35 x 7 mm
tampografia 35 x 7 mm



Extra customisation is available to
tell the story of this pen's origin.
Info at p. 276

*Disponibile una personalizzazione
extra per raccontare l'origine di
questa penna. Info a pag. 276*

**Download
Post-consumer
Recycled
Collection
Catalogue**

Scarica il catalogo
Post-consumer
Recycled
Collection



Technical information
Informazioni tecniche

Icon Pure

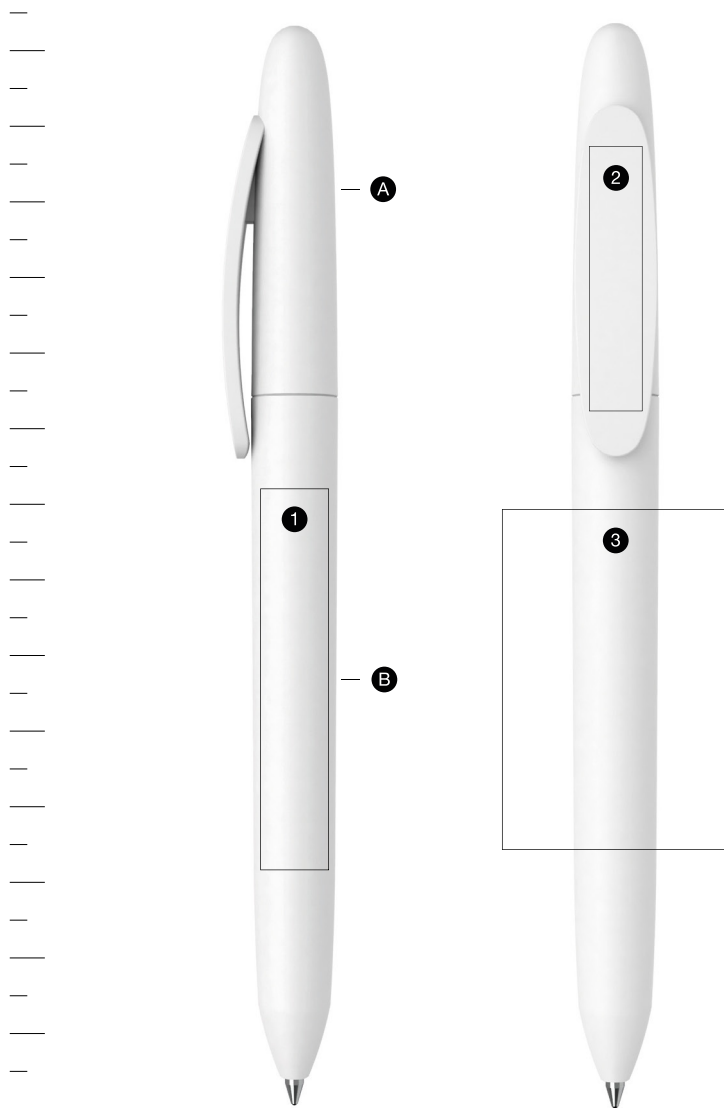

ø 10,2 mm
h 137 mm



POST-CONSUMER
RECYCLED PLASTIC

Zink is available
in post-consumer recycled plastic/
*La penna Zink è disponibile
in plastica riciclata post-consumo*

Components / Componenti

- A** Cap / cappuccio
- B** Barrel / fusto

Print area / Area stampabile

- 1** pad printing / tampografia
50 x 9 mm
- 2** pad printing / tampografia
35 x 7 mm
- 3** screen printing / serigrafia
45 x 30 mm

Features / Caratteristiche

twist-action / meccanismo
a rotazione

made of non-toxic highly resistant
ABS plastic / realizzata in plastica ABS,
atossica e ad alta resistenza

Jumbo refill, blue and black ink /
refill Jumbo, inchiostro blu e nero

available in rubberised and matt finish
/ disponibile con superfici gommate e
satinatate

printing must be carried out before
rubber coating or, alternatively,
using specific inks for rubberised
surfaces / la stampa deve essere
eseguita prima della gommatura o, in
alternativa, con inchiostri specifici per
superfici gommate

 IC8 – POST-CONSUMER RECYCLED PLASTIC
PLASTICA RICICLATA POST-CONSUMO

Small imperfections and slight colour variations
are to be considered intrinsic features of
the recycled material deriving from the post-
consumer sector. / Piccole imperfezioni e lievi
variazioni cromatiche sono da considerarsi
caratteristiche intrinseche del materiale riciclato
derivante dal post-consumo.

Fast Dry Gel blue and black ink available
on request /
*Refill Gel Fast Dry blu e nero disponibile
su richiesta*

Flow Pure



Free from extra.
Pura ed essenziale.

The essence of design.
L'essenza del design.

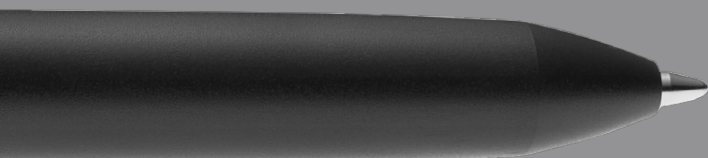

Also available in post-consumer recycled plastic /
Disponibile anche in plastica riciclata post-consumo



Also available in white antibacterial plastic /
Disponibile anche in plastica antibatterica bianca

Technical information at p. 113
Informazioni tecniche a pag. 113

F2P | MATT CB

Solid colour barrel and cap, solid white colour clip, matt finishes

Matt finish
and white clip
for maximum
freedom of
personalisation.



70

03

18

15

74

60

61

71

25

72

73

79

*Fusto e cappuccio in colore coprente,
clip in colore bianco coprente,
finiture satinat*

Finitura matt
e clip bianca
per la massima
libertà di
personalizzazione.



09

75

26

27

64

77

12

22

04

05 grey / pad printing 40 x 9 mm
05 grigio / tampografia 40 x 9 mm



All the expressive force of colour in a matt version.



01

70

03

18

15

74

60

61

25

72

73

71 light violet / pad printing 40 x 9 mm
71 viola chiaro / tampografia 40 x 9 mm

Colori coprenti con finitura satinata

Tutta la forza
espressiva del
colore in versione
satinata.



79

09

75

26

27

64

77

12

05

04

22 blue / pad printing 40 x 9 mm
22 blu / tampografia 40 x 9 mm

The matt finish
lights up with
fluo colours.



02



17



14



Universal single pen case
in Fedrigoni recycled paper
Ardesia. Info at p. 280

Astuccio universale
per penna singola
in cartoncino riciclato
Fedrigoni Ardesia.
Info pag. 280

Colori fluo coprenti
con finitura satinata

La finitura satinata
si accende
con i colori fluo.

FLUO



08

56 fucsia / pad printing 40 x 9 mm
56 fucsia / tampografia 40 x 9 mm

The colours stand out due to the brilliance of the gloss finish.



01 70 03 18 15 74



60 pink / pad printing 40 x 9 mm
60 rosa / tampografia 40 x 9 mm



61 71 25 72

Colori coprenti con finitura lucida

I colori risaltano grazie alla brillantezza della finitura lucida.



73

79

09

75

26

27

64

77

12

22

05

04

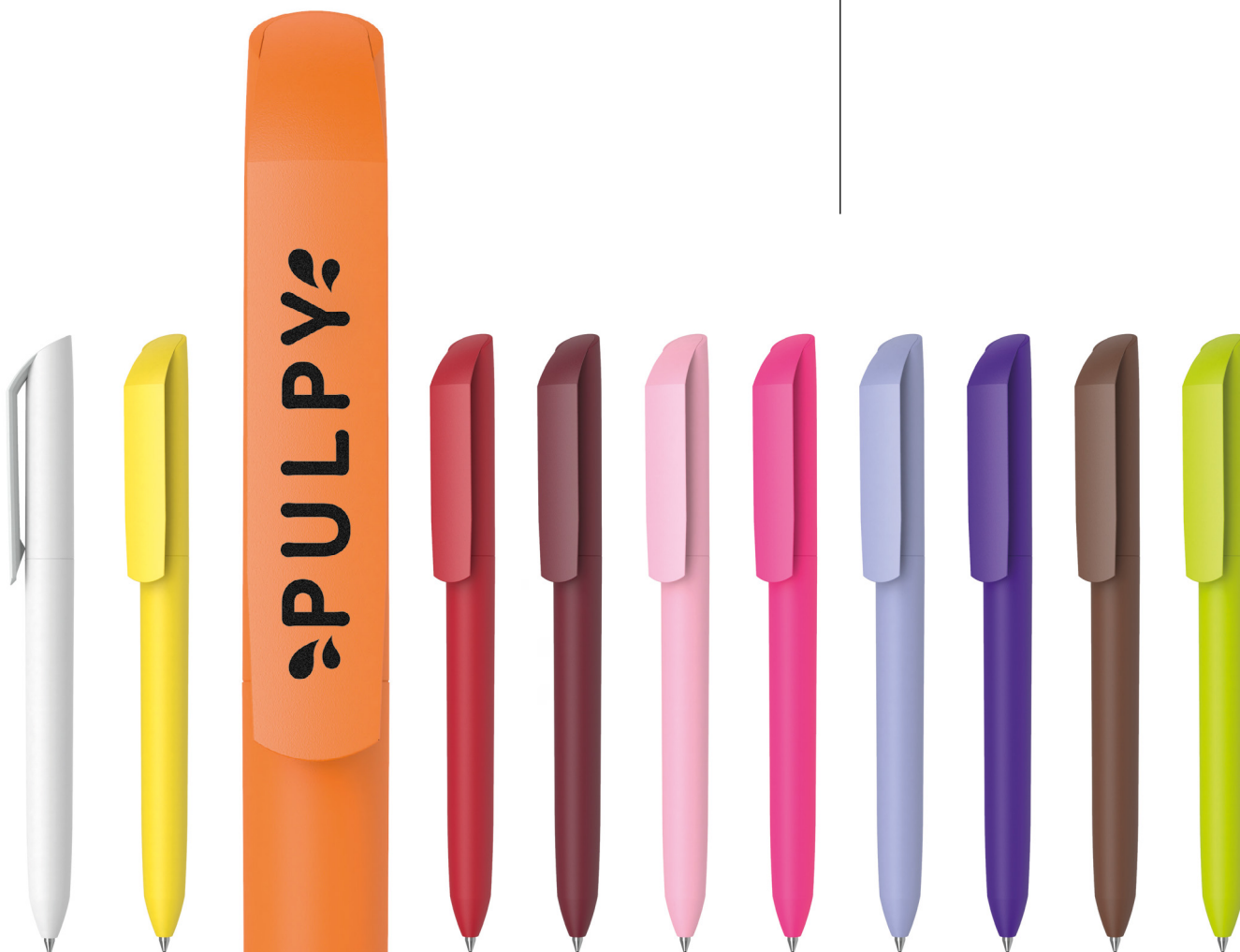

01

03

15

74

60

61

71

25

73

79

18 orange / pad printing 40 x 9 mm
18 arancio / tampografia 40 x 9 mm

Fusto e cappuccio in colore coprente
gommato, clip in colore coprente
satinato



26 aquamarine / pad printing 40 x 9 mm
26 acquamarina / tampografia 40 x 9 mm

F2P | GOM K

Solid black barrel and cap with rubber finish, solid colour clip with glossy finish



70 cream / pad printing 40 x 9 mm
70 crema / tampografia 40 x 9 mm



03



15



60



61



71



72

18 orange / pad printing 40 x 9 mm
18 arancio / tampografia 40 x 9 mm

*Fusto e cappuccio in colore
nero coprente gommato,
clip in colore coprente lucido*



79

09

27

64

77

12

05

04

26 aquamarine / pad printing 40 x 9 mm
26 acquamarina / tampografia 40 x 9 mm

F2P | GOM CB

Solid colour barrel and cap with rubber finish, solid white colour clip with glossy finish

60 pink / pad printing 40 x 9 mm
60 rosa / tampografia 40 x 9 mm



01 03 18 15 74



61



25 73

71 light violet /
pad printing
40 x 9 mm
71 viola chiaro /
tampografia
40 x 9 mm

*Fusto e cappuccio in colore coprente
gommato, clip in colore bianco
coprente lucido*

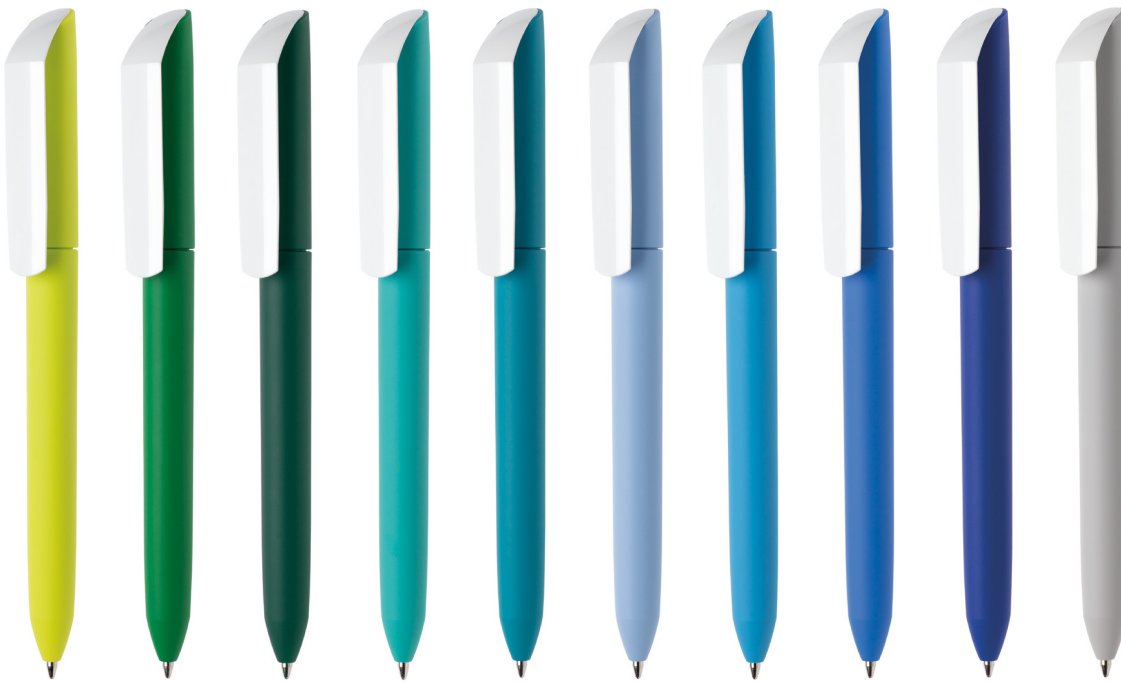

79

09

75

26

27

64

77

12

22

05

04 black / pad printing 40 x 9 mm
04 nero / tampografia 40 x 9 mm



Solid colour barrel and cap with rubber finish, transparent colour clip with glossy finish

Even the rubberised barrel can be pad or silk-screen printed.



39

52

53

45

59

41

31

55

37

38 brown / pad printing 40 x 9 mm
38 marrone / tampografia 40 x 9 mm



Fusto e cappuccio in colore coprente gommato, clip in colore trasparente lucido

Anche il fusto è stampabile con tampografia o serigrafia.

49 green / pad printing 50 x 9 mm
49 verde / tampografia 50 x 9 mm



78



47



34



67



44



30

50 dark grey / pad printing 40 x 9 mm
50 grigio scuro / tampografia 40 x 9 mm



Solid fluo colour barrel and cap with rubber finish, solid fluo colour clip with glossy finish

Fusto e cappuccio in colore fluo coprente gommato, clip in colore fluo coprente lucido

FLUO



02



17



14



08

56 fuchsia / pad printing 40 x 9 mm
56 fuchsia / tampografia 40 x 9 mm

F2P | GOM KF

Solid black colour barrel and cap with rubber finish, solid fluo colour clip with glossy finish

Fusto e cappuccio in colore nero coprente gommato, clip in colore fluo coprente lucido



02 yellow / pad printing 40 x 9 mm
02 giallo / tampografia 40 x 9 mm



17



56



08

14 coral red / pad printing 40 x 9 mm
14 rosso corallo / tampografia 40 x 9 mm

Solid fluo colour barrel and cap with rubber finish, transparent fluo colour clip with glossy finish

Minimal profile and compact volumes.



20



33 orange /
pad printing 40 x 9 mm
33 arancio /
tampografia 40 x 9 mm



24

*Fusto e cappuccio in colore fluo
coprente gommato, clip in colore fluo
trasparente lucido*

Profilo minimal
e volumi compatti.

FLUO



46

48 green / pad printing 40 x 9 mm
48 verde / tampografia 40 x 9 mm





F2P | MATT CB RE

PLASTIC POST-CONSUMER RECYCLED

Post-consumer recycled plastic
Solid colour barrel and cap, solid white
colour clip, matt finish

Made of WEEE
(Waste of Electrical
and Electronic
Equipment)
recycled plastic.



10



76

87 mud / pad printing 40 x 9 mm
tampografia 40 x 9 mm



Extra customisation is available to
tell the story of this pen's origin.
Info at p. 276

*Disponibile una personalizzazione
extra per raccontare l'origine di
questa penna. Info a pag. 276*



*Plastica riciclata post-consumo
Fusto e cappuccio in colore coprente,
clip in colore bianco coprente,
finitura satinata*

Realizzata in
plastica riciclata
da RAEE (Rifiuti
di Apparecchiature
Elettriche ed
Elettroniche).



19



21



58



07 onyx / pad printing 40 x 9 mm
tampografia 40 x 9 mm

**Download
Post-consumer
Recycled
Collection
Catalogue**

Scarica il catalogo
Post-consumer
Recycled
Collection





F2P | MATT RE

RECYCLED PLASTIC POST-CONSUMER

Post-consumer recycled plastic
Solid colours with matt finish

Design embraces sustainability.



06



76



87

10 cloud / pad printing 40 x 9 mm
tampografia 40 x 9 mm



Universal single pen case in
Fedrigoni recycled paper Gesso.
Info at p. 281

Astuccio universale
per penna singola
in cartoncino riciclato Fedrigoni
Gesso.
Info pag. 281



*Plastica riciclata post-consumo
Colori coprenti con finitura satinata*

Il design
abbraccia
la sostenibilità.



19



21



58



07

**Download
Post-consumer
Recycled
Collection
Catalogue**

Scarica il catalogo
Post-consumer
Recycled
Collection



F2P | C AB

Antibacterial plastic, solid white colour with glossy finish

Take care of yourself, even when you write.



01



solid / coprenti

01

white
bianco

*Plastica antibatterica, colore bianco
coprente con finitura lucida*

Anche quando
scrivi, prenditi
cura di te.



Universal reclosable single pen case
in Fedrigoni recycled paper Gesso.
Info at p. 288

*Astuccio universale richiudibile per
penna singola in cartoncino riciclato
Fedrigoni Gesso.
Info pag. 288*

**Download
Antibacterial
Pens
catalogue**

Scarica il
Catalogo
Antibacterial
Pens



Technical information
Informazioni tecniche

Flow Pure

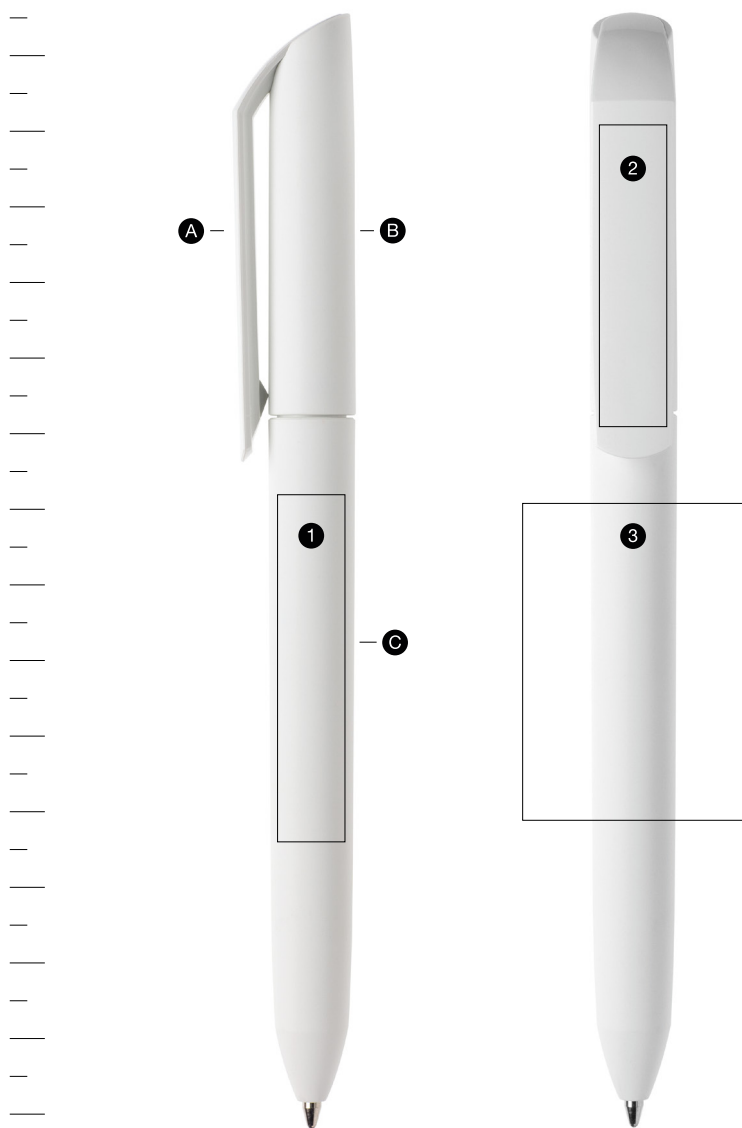

ø 10,2 mm
h 141 mm



POST-CONSUMER
RECYCLED PLASTIC

Zink is available
in post-consumer recycled plastic/
*La penna Zink è disponibile
in plastica riciclata post-consumo*

ANTIBACTERIAL
PLASTIC

Zink is available in white
antibacterial plastic/
*La penna Zink è disponibile
in plastica antibatterica bianca*

Components / Componenti

- Ⓐ Clip
- Ⓑ Cap / cappuccio
- Ⓒ Barrel / fusto

Print area / Area stampabile

- ① pad printing / tampografia
50 x 9 mm
- ② pad printing / tampografia
40 x 9 mm
- ③ screen printing / serigrafia
45 x 30 mm

Features / Caratteristiche

twist-action / meccanismo a rotazione

made of non-toxic highly resistant ABS
plastic / realizzata in plastica ABS,
atossica e ad alta resistenza

Jumbo refill, blue and black ink / refill
Jumbo, inchiostro blu e nero

available in glossy, matt or rubberised
finish / disponibile con superfici lucide,
satinare o gommate

 F2P – POST-CONSUMER RECYCLED
PLASTIC / PLASTICA RICICLATA
POST-CONSUMO

Small imperfections and slight colour variations
are to be considered intrinsic features of
the recycled material deriving from the post-
consumer sector. / Piccole imperfezioni e lievi
variazioni cromatiche sono da considerarsi
caratteristiche intrinseche del materiale riciclato
derivante dal post-consumo.

Fast Dry Gel blue and black ink available
on request /
*Refill Gel Fast Dry blu e nero disponibile
su richiesta*

Flow



Feel the change.
Senti il cambiamento.

Evolution of shape,
with and without texturing.

*L'evoluzione della forma,
con e senza texture.*



Technical information at p. 127
Informazioni tecniche a pag. 127

F1 | MATT AL

Solid colours with matt finish,
aluminium painted finish tip

Matt colours
and aluminium
colour tip: satin
style elegance.



01

70

03

18

15

74

60

61

71

25

73

Colori coprenti con finitura
satinata, punta verniciata
in colore alluminio

Colori matt
e punta color
alluminio:
eleganza in
versione satinata.

79 lime / pad printing 40 x 9 mm
79 lime / tampografia 40 x 9 mm



09 75 26 27 64

77 cyan / pad printing 40 x 9 mm
77 ciano / tampografia 40 x 9 mm



12 22 05 04

F1

C CR

Solid colours with glossy finish,
chromed tip



70

03

18

15

74

60

61

71

25

73

01 white / pad printing 40 x 9 mm
01 bianco / tampografia 40 x 9 mm

Colori coprenti con finitura lucida,
punta cromata



79

09

75

26

27

64



12

22

05

04

77 cyan / pad printing 40 x 9 mm
77 ciano / tampografia 40 x 9 mm

F1T | GOM C CR

Solid colour barrel with rubber finish, solid colour clip with glossy finish, textured solid colour cap with matt finish, chromed tip

Distinctive feature: textured cap.



01

70

03

15

74

60

61

71

25

73

18 orange / pad printing 40 x 9 mm
18 arancio / tampografia 40 x 9 mm

*Fusto in colore coprente gommato,
clip in colore coprente lucido,
cappuccio texturizzato in colore
coprente con finitura satinata,
punta cromata*

Elemento
distintivo:
cappuccio
arricchito da
una texture.



79

09

75

26

27

64

77

12

22

05

04 black / pad printing 40 x 9 mm
04 nero / tampografia 40 x 9 mm



F1T | GOM CB CR

Solid colour barrel with rubber finish, solid glossy white colour clip, textured solid colour cap with matt finish, chromed tip

Textured with small hexagonal cells that recall a honeycomb: a dynamic design of visual and tactile elegance.



03

18

15

74

60

61

71

25

79

73 brown / pad printing 40 x 9 mm
73 marrone / tampografia 40 x 9 mm

Fusto in colore coprente gommato, clip in colore bianco lucido, cappuccio texturizzato in colore coprente con finitura satinata, punta cromata

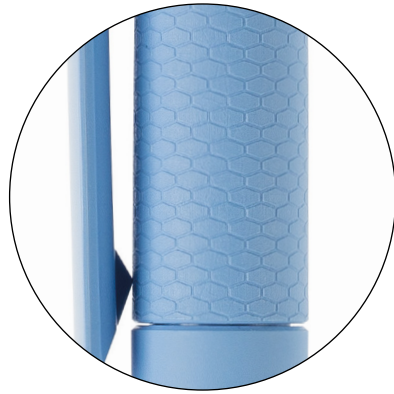

Texture costituita da piccole celle esagonali che ricordano un nido d'ape: un design dinamico che dona eleganza visiva e tattile.



09

75

27

64

77

12

22

04

26 aquamarine / pad printing 40 x 9 mm
26 acquamarina / tampografia 40 x 9 mm

05 grey / pad printing 40 x 9 mm
05 grigio / tampografia 40 x 9 mm

F1T | GOM 30 CR

Solid colour barrel with rubber finish, transparent glossy colour clip, textured solid colour cap with matt finish, chromed tip



39



52



53



45



41



31



55



37

59 pink / pad printing 40 x 9 mm
59 rosa / tampografia 40 x 9 mm

*Fusto in colore coprente gommato,
clip in colore trasparente lucido,
cappuccio texturizzato in colore
coprente con finitura satinata,
punta cromata*

30 light grey / pad printing 40 x 9 mm
30 grigio chiaro / tampografia 40 x 9 mm



38



78



49



47



67



44



50

34 pastel blue / pad printing 40 x 9 mm
34 azzurro pastello / tampografia 40 x 9 mm

Technical information
Informazioni tecniche

Flow

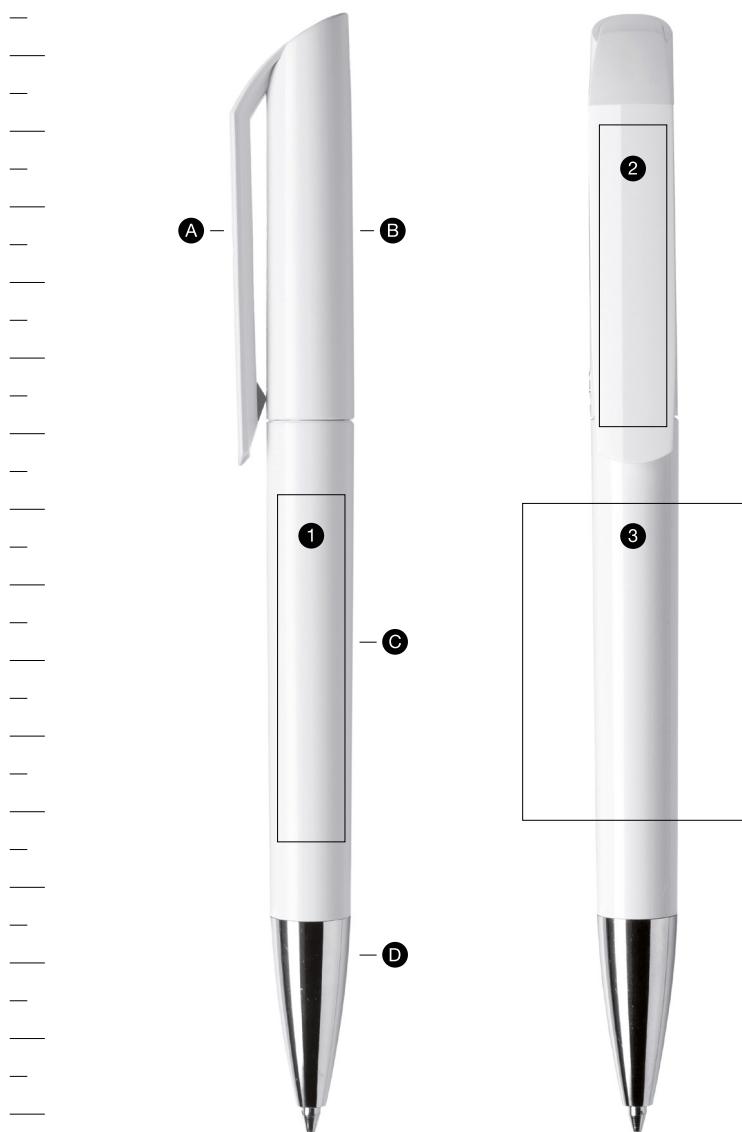

ø 11,4 mm
h 142 mm



The entire Maxema collection is available
in post-consumer recycled plastic on request /
*Tutta la collezione Maxema è realizzabile
in plastica riciclata post-consumo su richiesta*

Components / Componenti

- A Clip
- B Cap / cappuccio
- C Barrel / fusto
- D Tip / punta

Print area / Area stampabile

- 1 pad printing / tampografia
46 x 9 mm
- 2 pad printing / tampografia
40 x 9 mm
- 3 screen printing / serigrafia
42 x 30 mm

Features / Caratteristiche

twist-action / meccanismo a rotazione

made of non-toxic highly resistant ABS
plastic / realizzata in plastica ABS,
atossica e ad alta resistenza

galvanic process used to chrome tip /
la cromatura della punta è ottenuta
con trattamento galvanico

Jumbo refill, blue and black ink /
refill Jumbo, inchiostro blu e nero

available in glossy, matt or rubberised
finish / disponibile con superfici lucide,
satinato o gommato

in the Texture version, the entire matt
cap features a honeycomb design /
nella versione Texture il cappuccio
satinato è percorso interamente da una
trama a nido d'ape

Fast Dry Gel blue and black ink available
on request /
Refill Gel Fast Dry blu e nero disponibile
su richiesta

Dot



Different from the rest, full stop.
Diversa da tutte, punto.

A pen that reveals
its originality in its details.

*È nei dettagli che rivela
la sua originalità.*



Also available in post-consumer recycled plastic /
Disponibile anche in plastica riciclata post-consumo



Also available in antibacterial plastic /
Disponibile anche in plastica antibatterica

Technical information at p. 165
Informazioni tecniche a pag. 165

D1 | MATT B

Solid white colour barrel, clip and push-button with matt finish, solid glossy colour little sphere

The matt finish enhances the design and offers new tactile sensations.



01

03 yellow / pad printing 40 x 9 mm
03 giallo / tampografia 40 x 9 mm

The touch of colour stands out against the pure white.

Fusto, clip e tappino in colore bianco coprente con finitura satinata, piccola sfera in colore coprente lucido

La finitura satinata esalta il design e offre nuove sensazioni tattili.



18



15



74



60



61



71



25



73



79



09



75



26



27



64



77



12



22



05



04

Il punto di colore spicca nella nitidezza del bianco.

D1 | MATT CB

Solid colour barrel with matt finish, solid matt white clip and push-button, solid glossy colour little sphere



03

18

15

74

61

71

25

73

60 pink / pad printing 40 x 9 mm
60 rosa / tampografia 40 x 9 mm

Fusto in colore coprente con finitura satinata, clip e tappino in colore bianco coprente satinato, piccola sfera in colore coprente lucido



79

09

75

26

27

64

77

22

05

04

12 light blue / pad printing 40 x 9 mm
12 azzurro / tampografia 40 x 9 mm

D1 | MATT

Solid colours with matt finish, solid glossy colour little sphere

Attractive and refined: the integral matt finish.



70

03

18

15

74

60

61

25

72

73

71 light violet / pad printing 40 x 9 mm
71 viola chiaro / tampografia 40 x 9 mm

Colori coprenti con finitura
satinata, piccola sfera in colore
coprente lucido

Attrante
e raffinata:
è la finitura
satinata integrale.

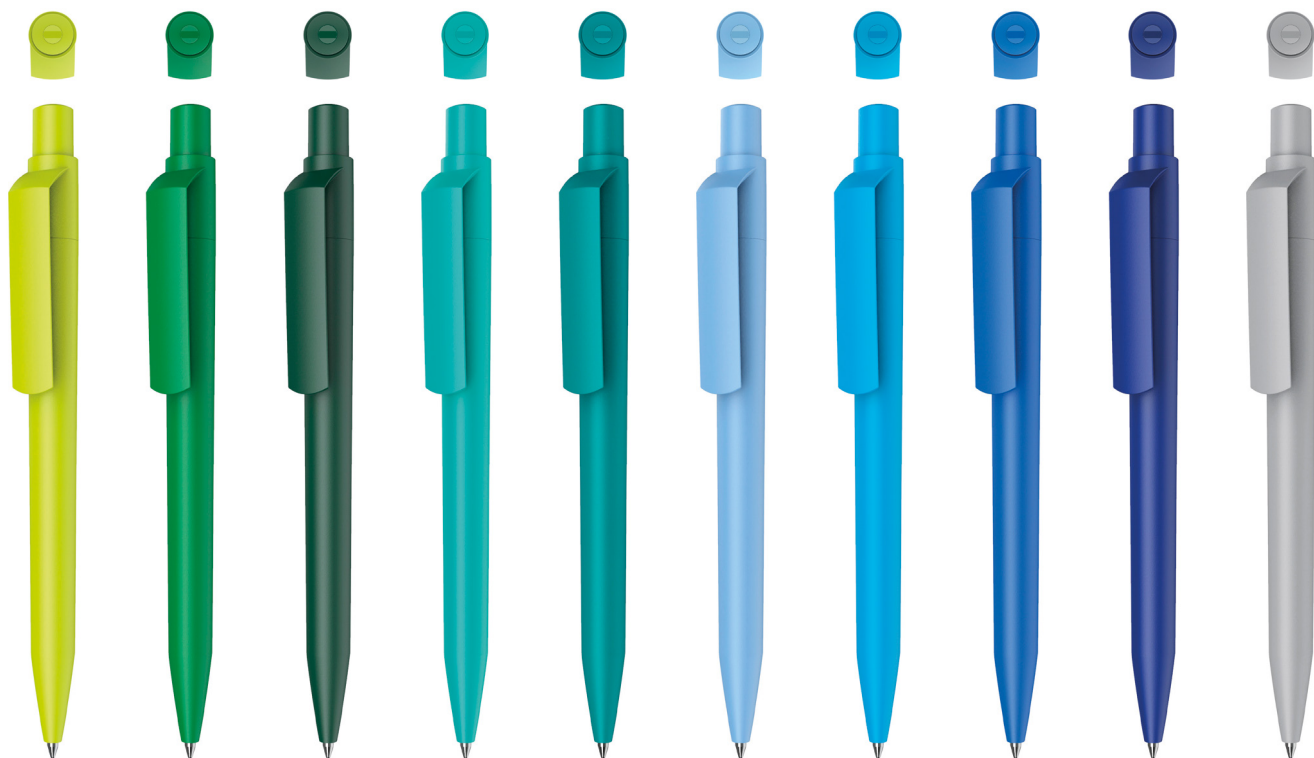

79

09

75

26

27

64

77

12

22

05

D1 | MATT K

Solid black colour barrel, clip and push-button with matt finish, solid glossy colour little sphere

Purity of lines and matt finish:
simply elegant.



01

70 cream / pad printing 40 x 9 mm
70 crema / tampografia 40 x 9 mm

Minimal black
is combined with
a discreet touch
of colour.

Fusto, clip e tappino in colore nero coprente con finitura satinata, piccola sfera in colore coprente lucido

Purezza di linee
e finitura matt:
semplicemente
elegante.



03



18



15



74



60



61



71



25



72



73



79



09



75



26



27



77



12



22



05



04

Il nero minimal è
abbinato a una
piccola e discreta
nota di colore.

Solid fluo colours with matt finish,
solid glossy fluo colour little sphere

A more profound
chromatic impact
thanks to the fluo
colours.

FLUO



02



17



56



08

14 coral red / pad printing 40 x 9 mm
14 rosso corallo / tampografia 40 x 9 mm

*Colori fluo coprenti con finitura
satinata, piccola sfera in colore fluo
coprente lucido*

Impatto cromatico
più incisivo
grazie ai colori
fluo.

FLUO

D1 | B CR

Solid white colour barrel and clip with glossy finish, solid glossy colour little sphere, chromed push-button



01

03 yellow / pad printing 40 x 9 mm
03 giallo / tampografia 40 x 9 mm

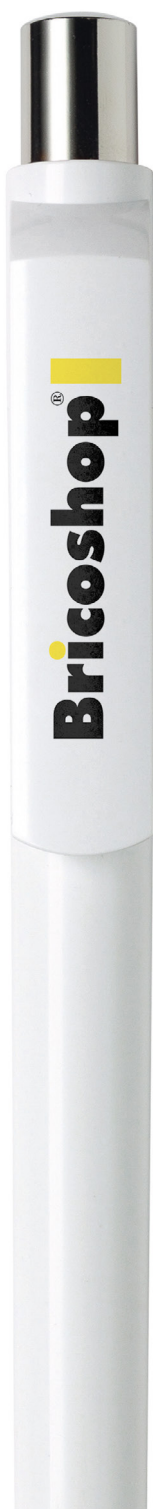

A white surface is the creative foundation par excellence: freedom of expression and top colour rendering.

Total white: basic and elegant thanks to its refined colour detail.

Fusto e clip in colore bianco coprente con finitura lucida, piccola sfera in colore coprente lucido, tappino cromato



18



15



74



60



61



71



25



73



79



09



75



27



64



77



12



22



05



04

La superficie bianca è la base creativa per eccellenza: libertà di espressione e massima resa cromatica.

Total white: essenziale ed elegante grazie al raffinato dettaglio di colore.

D1

CB CR

Solid colour barrel and little sphere with glossy finish, solid glossy white colour clip, chromed push-button



03

18



74

60

61

71

25

73

79

15 red / pad printing 40 x 9 mm
15 rosso / tampografia 40 x 9 mm

*Fusto e piccola sfera in colore
coprente lucido, clip in colore bianco
coprente lucido, tappino cromato*



09

75

27

64

77

12

22

05

04 black /
pad printing
40 x 9 mm
04 nero /
tampografia
40 x 9 mm



D1

C CR

Solid colours with glossy finish,
chromed push-button

74 burgundy / pad printing 40 x 9 mm
74 bordeaux / tampografia 40 x 9 mm



70



03



18 orange /
pad printing
40 x 9 mm
18 arancio /
tampografia
40 x 9 mm



15



60



61



71



25

Colori coprenti con finitura lucida,
tappino cromato

64 pastel blue / pad printing 40 x 9 mm
64 azzurro pastello / tampografia 40 x 9 mm



73

79

09

75

27



77

12

22

05



04 black /
pad printing
40 x 9 mm
04 nero /
tampografia
40 x 9 mm

D1

30 CR

Transparent colours with glossy finish, solid glossy colour little sphere, chromed push-button



39



53



45



41



55



37



38

52 yellow / pad printing 40 x 9 mm
52 giallo / tampografia 40 x 9 mm

Colori trasparenti con finitura lucida, piccola sfera
in colore coprente lucido, tappino cromato



49

47

67

44

50

78 lime /
pad printing
40 x 9 mm
78 lime /
tampografia
40 x 9 mm

D1 | GOM K

Solid black colour barrel with rubber finish, solid black colour clip and push-button with glossy finish, solid glossy colour little sphere

The elegance of black combines with a soft touch finish for a high-impact result.



01



70 cream / pad printing 40 x 9 mm
70 crema / tampografia 40 x 9 mm

Total black with a note of colour.

Fusto in colore nero coprente gommato, clip e tappino in colore nero coprente lucido, piccola sfera in colore coprente lucido

L'eleganza del nero si combina con la finitura soft touch per un risultato di grande impatto.



03



18



15



74



60



61



71



25



72



73



79



09



75



26



27



77



12



22



05



04

Total black
con nota di colore.

D1

GOM CB CR

Solid colour barrel with rubber finish, solid glossy white colour clip, solid glossy colour little sphere, chromed push-button



01

03

stackoverflow

15

74

60

61

71

73

18 orange /
pad printing
40 x 9 mm
18 arancio /
tampografia
40 x 9 mm

25 dark violet /
pad printing
40 x 9 mm
25 viola scuro /
tampografia
40 x 9 mm

64 pastel blue / pad printing 40 x 9 mm
 64 azzurro pastello / tampografia 40 x 9 mm

*Fusto in colore coprente gommato,
 clip in colore bianco coprente lucido,
 piccola sfera in colore coprente
 lucido, tappino cromato*



79 09 75 26 27



77 12 22



04

05 grey /
 pad printing
 40 x 9 mm
 05 grigio /
 tampografia
 40 x 9 mm

D1 | GOM C CR

Solid colour barrel with rubber finish, solid colour clip and little sphere with glossy finish, chromed push-button

71 light violet / pad printing 40 x 9 mm
71 viola chiaro / tampografia 40 x 9 mm



18

15

74

60

61

03 yellow / pad printing 40 x 9 mm
03 giallo / tampografia 40 x 9 mm



25

72

73

Fusto in colore coprente gommato, clip e piccola sfera in colore coprente con finitura lucida, tappino cromato

22 blue / pad printing 40 x 9 mm
22 blu / tampografia 40 x 9 mm



79

09

75

27

64

77

12

05

04

D1

GOM 30 CR

Solid colour barrel with rubber finish, transparent colour clip with glossy finish, solid glossy colour little sphere, chromed push-button



39

52

53

45

59

41

31

55

37

38 brown / pad printing 40 x 9 mm
38 marrone / tampografia 40 x 9 mm

Fusto in colore coprente gommato, clip in colore trasparente con finitura lucida, piccola sfera in colore coprente lucido, tappino cromato



78

49

47

34

67

44

30

50 dark grey / pad printing 40 x 9 mm
50 grigio scuro / tampografia 40 x 9 mm

D1 | C GOLD

Solid colours with glossy finish,
gilded push-button

*Colori coprenti con finitura lucida,
tappino dorato*



01 white / pad printing 40 x 9 mm
01 bianco / tampografia 40 x 9 mm



04

D1 | GOM KF CR

Solid black colour barrel with rubber finish, solid fluo colour clip and little sphere with glossy finish, chromed push-button

Fusto in colore nero coprente gommato, clip e piccola sfera in colore fluo coprente lucido, tappino cromato

FLUO



02

17 orange /
pad printing
40 x 9 mm
17 arancio /
tampografia
40 x 9 mm



56

14 coral red / pad printing 40 x 9 mm



08

14 rosso corallo / tampografia 40 x 9 mm



D1 | MATT CB RE

PLASTIC POST-CONSUMER RECYCLED

Post-consumer recycled plastic
Solid colour barrel with matt finish,
solid matt white clip and push-button,
solid glossy white little sphere

Made of WEEE
(Waste of Electrical
and Electronic
Equipment)
recycled plastic.



10



76



87

Extra customisation is available to
tell the story of this pen's origin.
Info at p. 277

*Disponibile una personalizzazione
extra per raccontare l'origine di
questa penna. Info a pag. 277*



*Plastica riciclata post-consumo
Fusto in colore coprente con finitura
satinata, clip e tappino in colore bianco
coprente satinato, piccola sfera in
colore bianco coprente lucido*

Realizzata in
plastica riciclata
da RAEE (Rifiuti
di Apparecchiature
Elettriche ed
Elettroniche).



19



21 abyss / pad printing 40 x 9 mm
tampografia 40 x 9 mm



58



07

**Download
Post-consumer
Recycled
Collection
Catalogue**

Scarica il catalogo
Post-consumer
Recycled
Collection





D1 | MATT RE

PLASTIC POST-CONSUMER RECYCLED

Post-consumer recycled plastic
Solid colours with matt finish,
solid glossy colour little sphere

The beauty
of sustainability:
8 colour
shades inspired
by nature.



10



76



87

06 ice / pad printing 40 x 9 mm
tampografia 40 x 9 mm



Universal single pen case
in Fedrigoni recycled paper
Ardesia. Info at p. 280

Astuccio universale
per penna singola
in cartoncino riciclato
Fedrigoni Ardesia.
Info pag. 280



*Plastica riciclata post-consumo
Colori coprenti con finitura satinata,
piccola sfera in colore coprente lucido*

La bellezza
della sostenibilità:
8 sfumature
di colore ispirate
alla natura.



19



21



58



07

**Download
Post-consumer
Recycled
Collection
Catalogue**

Scarica il catalogo
Post-consumer
Recycled
Collection



D1 | MATT CB AB

Antibacterial plastic, solid colour barrel with matt finish, solid glossy white clip, push-button and little sphere

No bacteria,
that's the message

15 red / pad printing 40 x 9 mm
15 rosso / tampografia 40 x 9 mm

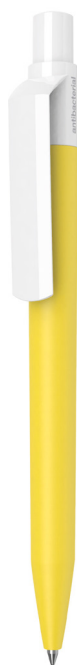

03



18



74



60



61



71

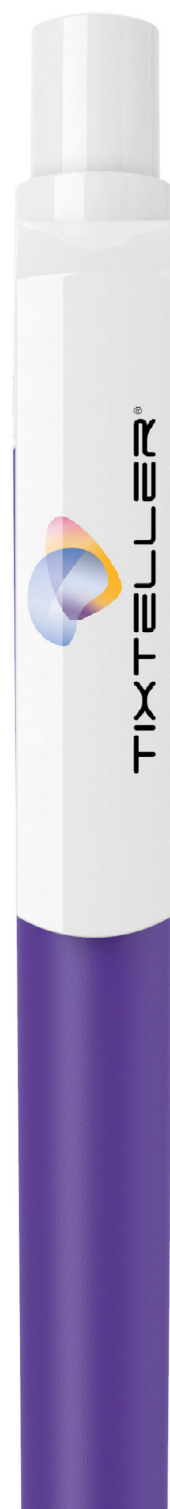

25 dark violet / pad printing 40 x 9 mm
25 viola scuro / tampografia 40 x 9 mm

*Plastica antibatterica, fusto in colore
coprente con finitura satinata, clip,
tappino e piccola sfera
in colore bianco coprente lucido*

Niente batteri,
è questo il
messaggio

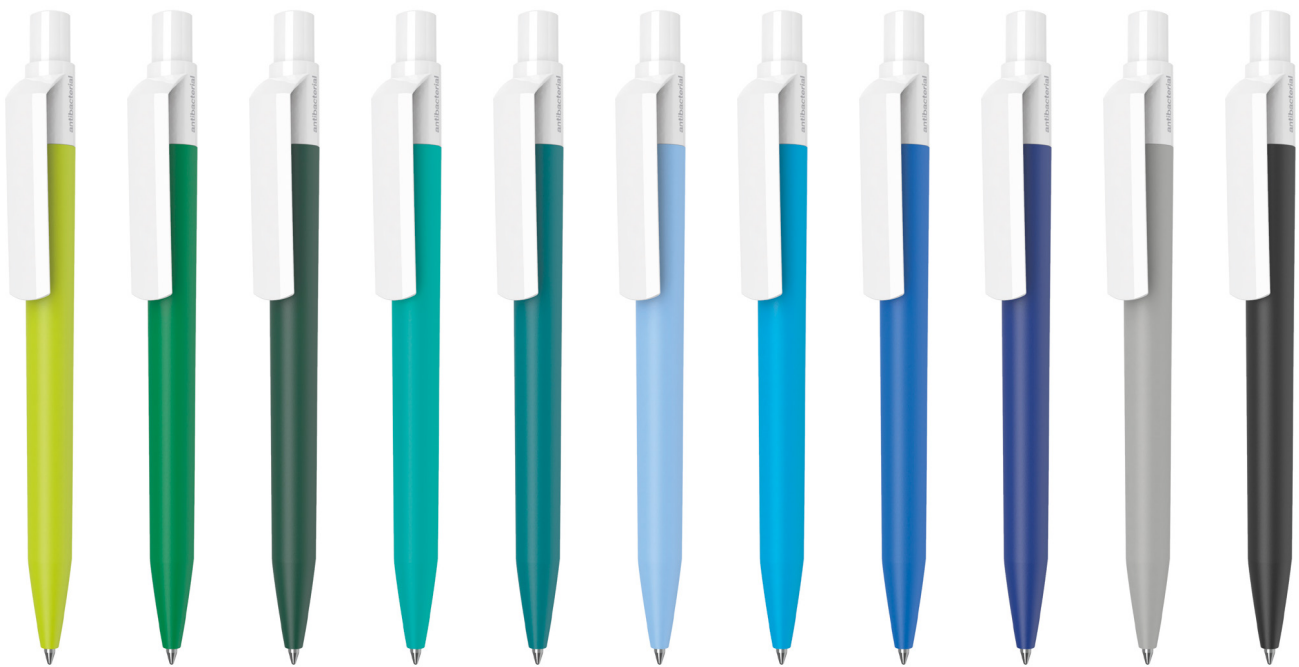

79

09

75

26

27

64

77

12

22

05

04

**Download
Antibacterial
Pens
catalogue**

Scarica il
Catalogo
Antibacterial
Pens



Technical information
Informazioni tecniche

Dot

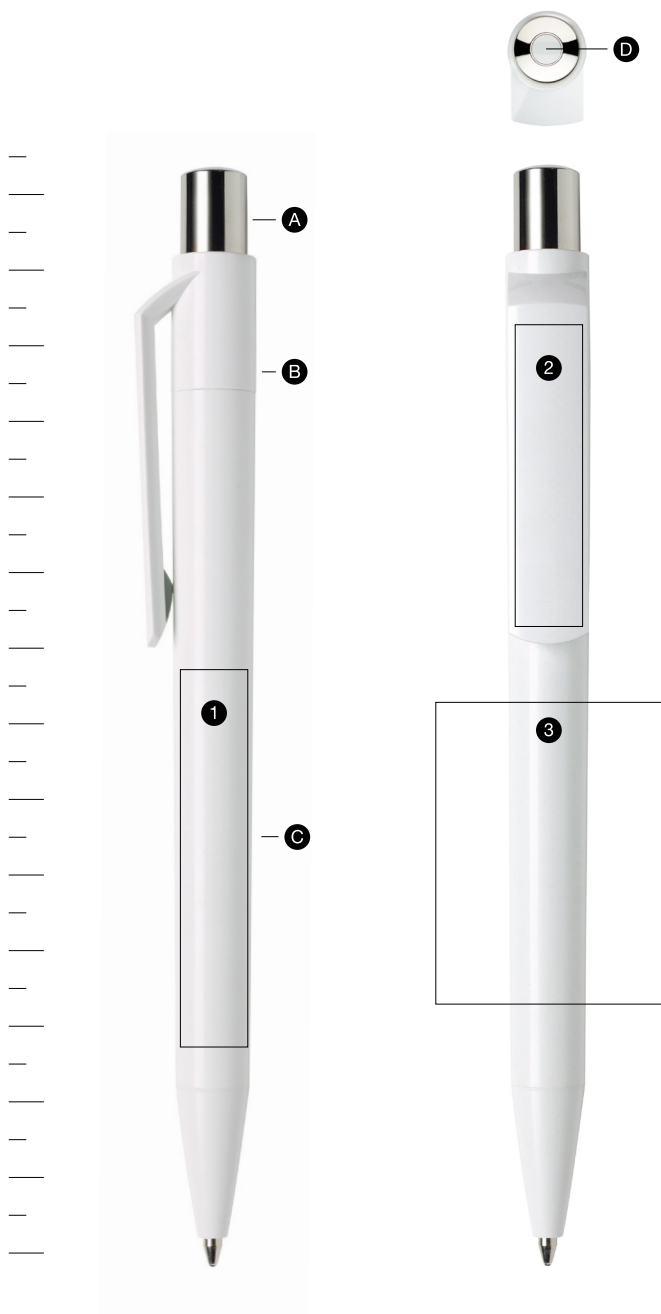

ø 10,5 mm
h 141 mm



POST-CONSUMER
RECYCLED PLASTIC

Zink is available
in post-consumer recycled plastic/
*La penna Zink è disponibile
in plastica riciclata post-consumo*

ANTIBACTERIAL
PLASTIC

Zink is available in white
antibacterial plastic/
*La penna Zink è disponibile
in plastica antibatterica bianca*

Components / Componenti

- A** Push-button / tappino
- B** Clip
- C** Barrel / fusto
- D** Little sphere / piccola sfera

Print area / Area stampabile

- 1** pad printing / tampografia
50 x 9 mm
- 2** pad printing / tampografia
40 x 9 mm
- 3** screen printing / serigrafia
40 x 30 mm

Features / Caratteristiche

retractable with return spring /
meccanismo a scatto, con molla di ritorno

made of non-toxic, highly resistant
ABS plastic / realizzata in plastica ABS
atossica e ad alta resistenza

galvanic process used to chrome
and gild ABS push-button / la cromatura e
la doratura del tappino sono ottenute con
trattamento galvanico

Jumbo refill, blue and black ink / refill Jumbo,
inchiostro blu e nero

available in glossy, matt
or rubberised finish / disponibile con superfi-
ci lucide, satinare o gommate

 D1 – POST-CONSUMER RECYCLED PLASTIC
PLASTICA RICICLATA POST-CONSUMO

Small imperfections and slight colour variations
are to be considered intrinsic features of
the recycled material deriving from the post-consumer
sector. / Piccole imperfezioni e lievi variazioni cromatiche
sono da considerarsi caratteristiche intrinseche del
materiale riciclato derivante dal post-consumo.

Fast Dry Gel blue and black ink available
on request /
*Refill Gel Fast Dry blu e nero disponibile
su richiesta*

Zink

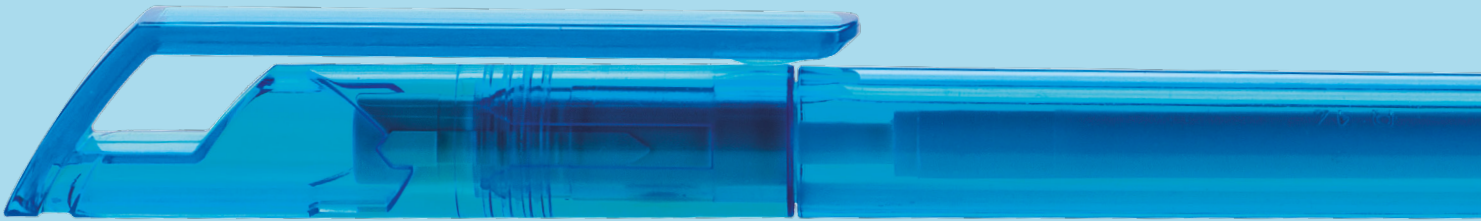

Solid geometries.
Solide geometrie.

A pen with a
clean-cut profile
and strong personality.

*Una penna
dal profilo tagliente
e dal carattere deciso.*



Also available in post-consumer recycled plastic /
Disponibile anche in plastica riciclata post-consumo



Also available in white antibacterial plastic /
Disponibile anche in plastica antibatterica bianca

Technical information at p. 183
Informazioni tecniche a pag. 183

Z1

CB

Solid colours barrel, solid white colour cap, glossy finishes

More suitability for multi-colour printing with white clip.



70

03

18

15

74

61

71

25

73

60 pink / pad printing 43 x 9 mm
60 rosa / tampografia 43 x 9 mm

*Fusto in colori coprenti,
cappuccio in colore bianco coprente,
finiture lucide*

Maggiore versatilità
per la stampa
a più colori con
la clip bianca.



79

09

75

26

27

64

77

22

05

04

12 light blue / pad printing 43 x 9 mm
12 azzurro / tampografia 43 x 9 mm

Solid colours with glossy finish

Solid, sturdy architecture for a profile of geometric precision.



01

70

03



15

74

60

61

25

73

18 orange / pad printing 43 x 9 mm
18 arancio / tampografia 43 x 9 mm

Colori coprenti con finitura lucida

Architettura
corposa e robusta
per un profilo dal
rigore geometrico.



79

09

75



64

77

12

22



04

05 grey / pad printing 43 x 9 mm
05 grigio / tampografia 43 x 9 mm

27 octan green / pad printing 43 x 9 mm
27 ottanio / tampografia 43 x 9 mm

Transparent colours with glossy finish

Its sturdy structure is offset by the slim, streamlined barrel.



39

52

53

45

59

41

51

31

55



37 amber / pad printing 43 x 9 mm
37 ambra / tampografia 43 x 9 mm

Colori trasparenti con finitura lucida

Il fusto slanciato
bilancia la solida
struttura.

67 cyan / pad printing 43 x 9 mm
67 ciano / tampografia 43 x 9 mm



38

78

49

47



44

30

50

Fluo colours,
intense and
vibrant shades.



02



14



56

17 orange / pad printing 43 x 9 mm
17 arancio / tampografia 43 x 9 mm

*Colori fluo coprenti
con finitura lucida*

Colori fluo,
tonalità intense
e vibranti.

FLUO



08 green / pad printing 43 x 9 mm
08 verde / tampografia 43 x 9 mm



Z1 | CB RE

RECYCLED PLASTIC POST-CONSUMER



10



76



87

Post-consumer recycled plastic
Solid colours barrel, solid white
colour cap, glossy finishes

Made of WEEE
(Waste of Electrical
and Electronic
Equipment)
recycled plastic.

Extra customisation is available to
tell the story of this pen's origin.
Info at p. 276

*Disponibile una personalizzazione
extra per raccontare l'origine di
questa penna. Info a pag. 276*



*Plastica riciclata post-consumo
Fusto in colori coprenti, cappuccio in
colore bianco coprente, finiture lucide*

Realizzata in
plastica riciclata
da RAEE (Rifiuti
di Apparecchiature
Elettriche ed
Elettroniche).



19



21 abyss / pad printing 43 x 9 mm
tampografia 43 x 9 mm

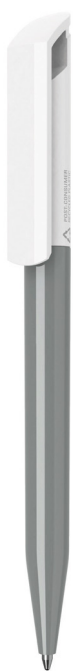

58



07

**Download
Post-consumer
Recycled
Collection
Catalogue**

Scarica il catalogo
Post-consumer
Recycled
Collection





Z1 | C RE

RECYCLED POST-CONSUMER PLASTIC

Post-consumer recycled plastic
Solid colours with glossy finish

Elegance and environmental friendliness: uncompromisingly together.



06



76



87

10 cloud / pad printing 43 x 9 mm
tampografia 43 x 9 mm



Universal reclosable single pen case in Fedrigoni recycled paper Ardesia. Info at p. 288

Astuccio universale richiudibile per penna singola in cartoncino riciclato Fedrigoni Ardesia. Info pag. 288



*Plastica riciclata post-consumo
Colori coprenti con finitura lucida*

Eleganza e
attenzione per
l'ambiente:
insieme senza
compromessi.



19



21



58

07 onyx / pad printing 43 x 9 mm
tampografia 43 x 9 mm



**Download
Post-consumer
Recycled
Collection
Catalogue**

Scarica il catalogo
Post-consumer
Recycled
Collection



Z1 | C AB

Antibacterial plastic, solid white colour with glossy finish

Write without limits and bacteria.



01



solid / coprenti

01

white
bianco

*Plastica antibatterica, colore bianco
coprente con finitura lucida*

Scrivi senza limiti
e batteri.



Universal reclosable single pen case
in Fedrigoni recycled paper Gesso.
Info at p. 288

*Astuccio universale richiudibile per
penna singola in cartoncino riciclato
Fedrigoni Gesso.
Info pag. 288*

**Download
Antibacterial
Pens
catalogue**

Scarica il
Catalogo
Antibacterial
Pens



Technical information
Informazioni tecniche

Zink

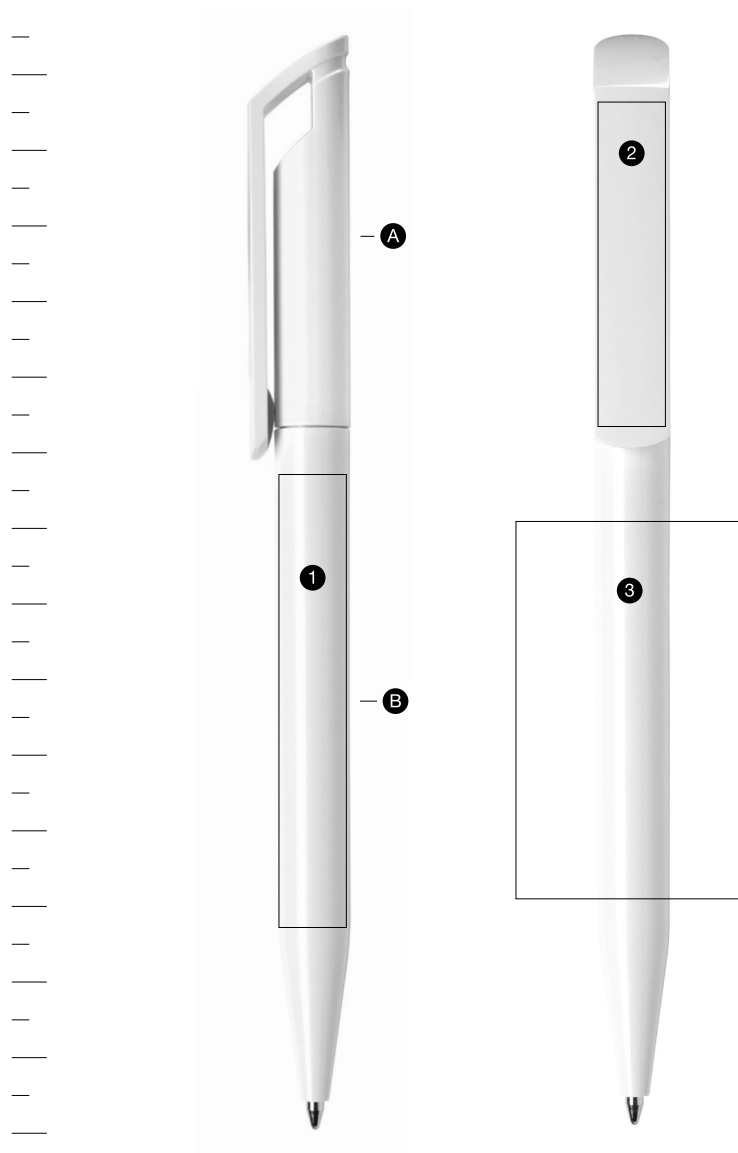

ø 10 mm
h 147 mm



Zink is available
in post-consumer recycled plastic/
*La penna Zink è disponibile
in plastica riciclata post-consumo*

ANTIBACTERIAL
PLASTIC

Zink is available in white
antibacterial plastic/
*La penna Zink è disponibile
in plastica antibatterica bianca*

Components / Componenti

- Ⓐ Cap / cappuccio
- Ⓑ Barrel / fusto

Print area / Area stampabile

- ① pad printing / tampografia
60 x 9 mm
- ② pad printing / tampografia
43 x 9 mm
- ③ screen printing / serigrafia
50 x 30 mm

Features / Caratteristiche

twist-action / meccanismo a rotazione

made of non-toxic, highly resistant
ABS plastic / realizzata in plastica ABS
atossica e ad alta resistenza

Jumbo refill, blue and black ink / refill
Jumbo, inchiostro blu e nero

available in glossy finish / disponibile
con superfici lucide

Z1 — POST-CONSUMER RECYCLED PLASTIC
PLASTICA RICICLATA POST-CONSUMO

Small imperfections and slight colour variations
are to be considered intrinsic features of
the recycled material deriving from the post-
consumer sector. / Piccole imperfezioni e lievi
variazioni cromatiche sono da considerarsi
caratteristiche intrinseche del materiale riciclato
derivante dal post-consumo.

Fast Dry Gel blue and black ink available
on request /
*Refill Gel Fast Dry blu e nero disponibile
su richiesta*

View



Decisive personality.
Carattere incisivo.

Exudes boldness from every angle and captivates with its elegance.

Sprigiona grinta da ogni punto di vista e affascina per l'eleganza.



Technical information at p. 193
Informazioni tecniche a pag. 193

V1

C CR / C CR T

Solid colours with glossy finish,
metal chrome finish clip, chromed tip

V1 - C CR clip per incisione laser /
clip for laser engraving

V1 - C CR T clip per tampografia /
clip for pad printing



01

70

03

18

15

74

61

71

60 pink / laser engraving 30 x 7 mm
60 rosa / incisione laser 30 x 7 mm

Colori coprenti con finitura lucida,
clip in metallo cromato,
punta cromata

79 lime / screen printing 42 x 30 mm
79 lime / serigrafia 42 x 30 mm



25



73



09



75



27



64



12



04

22 blue / pad printing on the clip 40 x 6 mm
22 blu / tampografia su clip 40 x 6 mm

V1

30 CR / 30 CR T

V1 – 30 CR clip per incisione laser /
clip for laser engraving

V1 – 30 CR T
clip per tampografia /
clip for pad printing

Transparent colours with glossy finish,
metal chrome finish clip, chromed tip

*Colori trasparenti con finitura lucida,
clip in metallo cromato, punta cromata*



52

53

45

51

55

49

47

44

40

39 neutral / screen printing 42 x 30 mm
39 neutro / serigrafia 42 x 30 mm

V1

AL CR / AL CR T

V1 – AL CR clip per incisione laser /
clip for laser engraving

V1 – AL CR T
clip per tampografia /
clip for pad printing

aluminium / laser engraving 30 x 7 mm
alluminio / incisione laser 30 x 7 mm



Aluminium painted finish barrel and cap, metal chromed clip, chromed tip

Fusto e cappuccio verniciati in colore alluminio, clip in metallo cromato, punta cromata

The sleek design of the cap adds elegance and balances the large clip.

La linea affilata del cappuccio dà armonia e bilancia l'imponenza della clip.

V1

GOM C CR / GOM C CR T

V1 - GOM C CR

clip per incisione laser /
clip for laser engraving

V1 - GOM C CR T

clip per tampografia /
clip for pad printing

Solid colour barrel and cap with
rubber finish, metal chrome clip,
chromed tip

Free rein to
colours on
metals too.



03

15

74

60

71

25

72

18 orange /
pad printing on the clip 40 x 6 mm
18 arancio /
tampografia su clip 40 x 6 mm

61 magenta /
screen printing 42 x 30 mm
61 magenta /
serigrafia 42 x 30 mm

*Fusto e cappuccio in colore coprente
gommato, clip in metallo cromato,
punta cromata*

Via libera ai colori,
anche su metallo.

64 pastel blue / laser engraving 30 x 7 mm
64 azzurro pastello / incisione laser 30 x 7 mm



73

79

09

75

27



12

22



04 black / pad printing
on the clip 40 x 6 mm
04 nero / tampografia
su clip 40 x 6 mm

Technical information
Informazioni tecniche

View

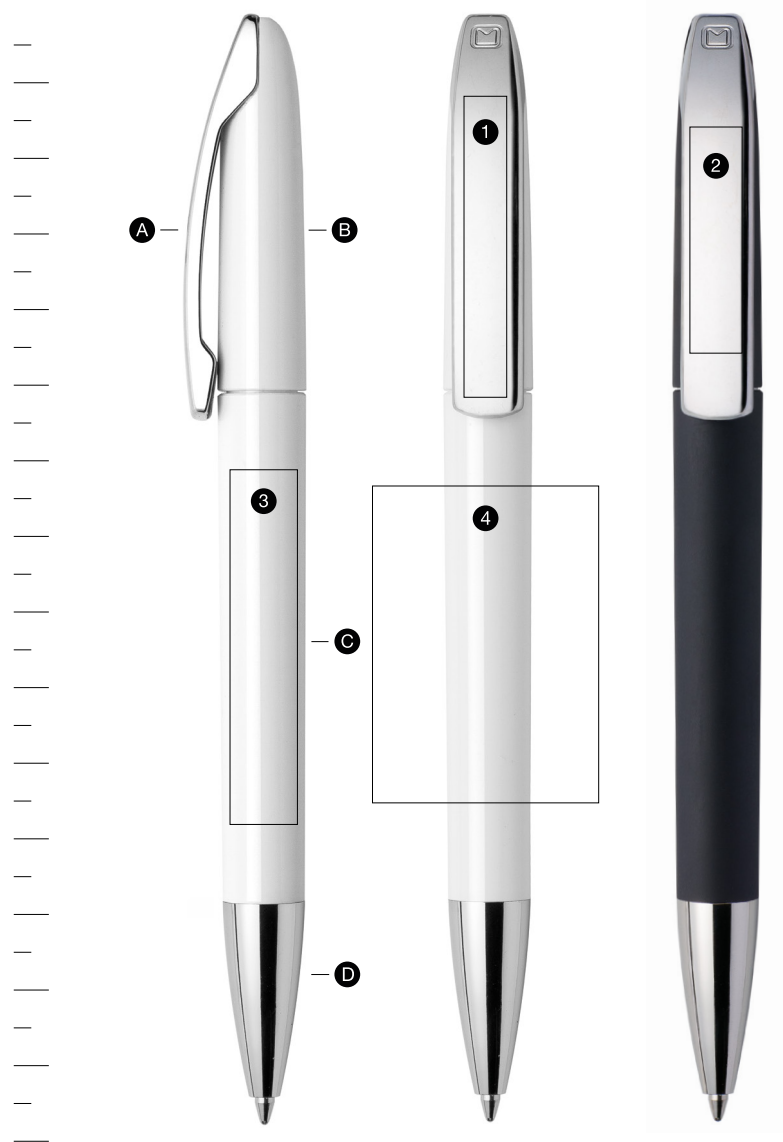

ø 11,3 mm
h 137,4 mm



The entire Maxema collection is available
in post-consumer recycled plastic on request /
*Tutta la collezione Maxema è realizzabile
in plastica riciclata post-consumo su richiesta*

Components / Componenti

- Ⓐ Clip
- Ⓑ Cap / cappuccio
- Ⓒ Barrel / fusto
- Ⓓ Punta / tip

Print area / Area stampabile

- ① pad printing / tampografia
40 x 6 mm
- ② laser engraving 30 x 7 mm
incisione laser 30 x 7 mm
- ③ pad printing / tampografia
47 x 9 mm
- ④ screen printing / serigrafia
42 x 30 mm

Features / Caratteristiche

twist-action / meccanismo a rotazione

made of non-toxic, highly resistant ABS
plastic / realizzata in plastica ABS
atossica e ad alta resistenza

metal chrome finish clip available
for laser engraving and pad printing /
clip in metallo cromato, disponibile
per incisione laser e tampografia

galvanic process used to chrome tip /
la cromatura della punta è ottenuta
con trattamento galvanico

Jumbo refill, blue and black ink / refill
Jumbo, inchiostro blu e nero

available in glossy, rubberised
or aluminium painted finish / disponibile
con superfici lucide, gommate
o verniciate in colore alluminio

Fast Dry Gel blue and black ink available
on request /
*Refill Gel Fast Dry blu e nero disponibile
su richiesta*

Tag

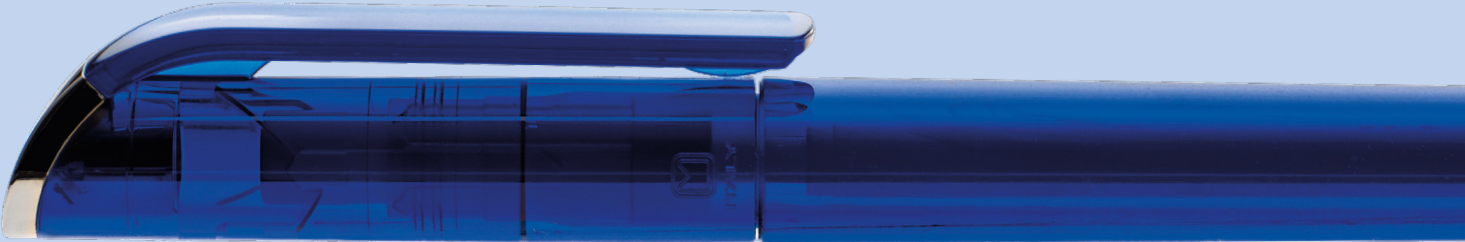

Imposing elegance.
Eleganza imponente.

Clean-cut, refined
design, a tribute
to perfect elegance.

*Design semplice
e raffinato, omaggio
all'eleganza perfetta.*



Technical information at p. 203
Informazioni tecniche a pag. 203

TA1 | MATT AL B

Solid white colour barrel and clip with matt finish, solid colour upper plug with glossy finish, aluminium painted finish tip

01 white / pad printing 40 x 9 mm
01 bianco / tampografia 40 x 9 mm
—
screen printing 42 x 30 mm
serigrafia 42 x 30 mm



03 18 15 74

61 magenta / pad printing 40 x 9 mm
61 magenta / tampografia 40 x 9 mm



71 25

*Fusto e clip in colore bianco
coprente con finitura satinata,
tassello superiore in colori
coprenti con finitura lucida,
punta verniciata in colore alluminio*



72 73 79 09 27



12 22 04

64 pastel blue / pad printing 40 x 9 mm
64 azzurro pastello / tampografia 40 x 9 mm

TA1 | B CR

Solid white colour barrel and clip,
solid colour upper plug, glossy
finishes, chromed tip

Elegance and
linearity to express
all the strength
of a brand.

15 red / pad printing 40 x 9 mm
15 rosso / tampografia 40 x 9 mm



03

18

74

61

09

27

12

22



Fusto e clip in colore bianco, tassello superiore in colori coprenti, finiture lucide, punta cromata

Eleganza e linearità per esprimere tutta la forza di un brand.

04 black / pad printing 40 x 9 mm
04 nero / tampografia 40 x 9 mm

TA1 | C CR

Solid colours with glossy finish,
chromed upper plug and tip

01 white / pad printing 40 x 9 mm
01 bianco / tampografia 40 x 9 mm



70

03

18

15

74

60

61

71

25

72

Colori coprenti con finitura lucida,
tassello superiore e punta cromati

64 pastel blue / pad printing 40 x 9 mm
64 azzurro pastello / tampografia 40 x 9 mm



79 09 75 27

73 brown / pad printing 40 x 9 mm
73 marrone / tampografia 40 x 9 mm



12 22 04

Technical information
Informazioni tecniche

Tag

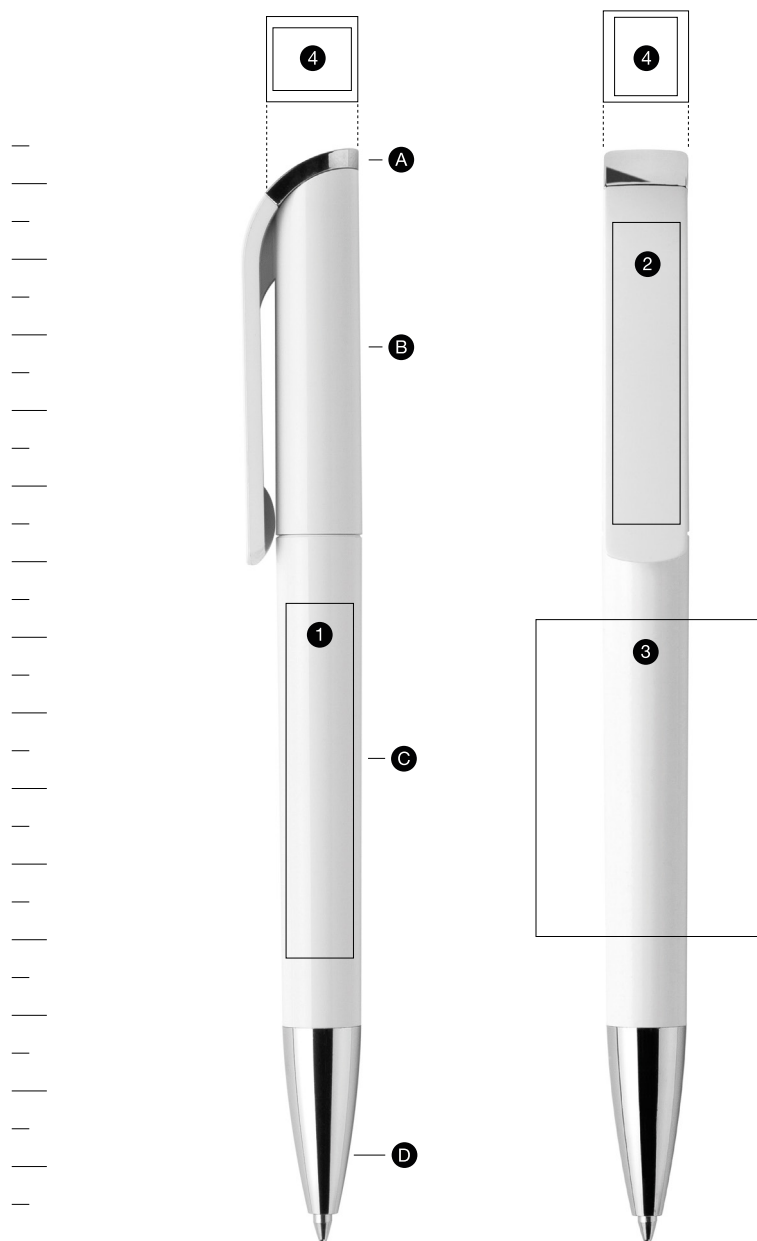

ø 11,3 mm
h 140 mm



The entire Maxema collection is available
in post-consumer recycled plastic on request /
*Tutta la collezione Maxema è realizzabile
in plastica riciclata post-consumo su richiesta*

Components / Componenti

- Ⓐ Plug / tassello
- Ⓑ Clip / clip
- Ⓒ Barrel / fusto
- Ⓓ Tip / punta

Print area / Area stampabile

- ① pad printing / tampografia
47 x 9 mm
- ② pad printing / tampografia
40 x 9 mm
- ③ screen printing / serigrafia
42 x 30 mm
- ④ pad printing / tampografia
8 x 10 mm

Features / Caratteristiche

twist-action / meccanismo a rotazione

made of non-toxic, highly resistant
ABS plastic / realizzata in plastica ABS
atossica e ad alta resistenza

galvanic process used to chrome tip
and upper plug / la cromatura della
punta e del tassello superiore
è ottenuta con trattamento galvanico

Jumbo refill, blue and black ink /
refill Jumbo, inchiostro blu e nero

available in glossy and matt finish /
disponibile con superfici
lucide e satinare

Fast Dry Gel blue and black ink available
on request /
*Refill Gel Fast Dry blu e nero disponibile
su richiesta*

Icon



Timeless design.
Design senza tempo.

A perfect synthesis of
past, present and future.

*L'incontro tra passato,
presente e futuro.*



Technical information at p. 215
Informazioni tecniche a pag. 215

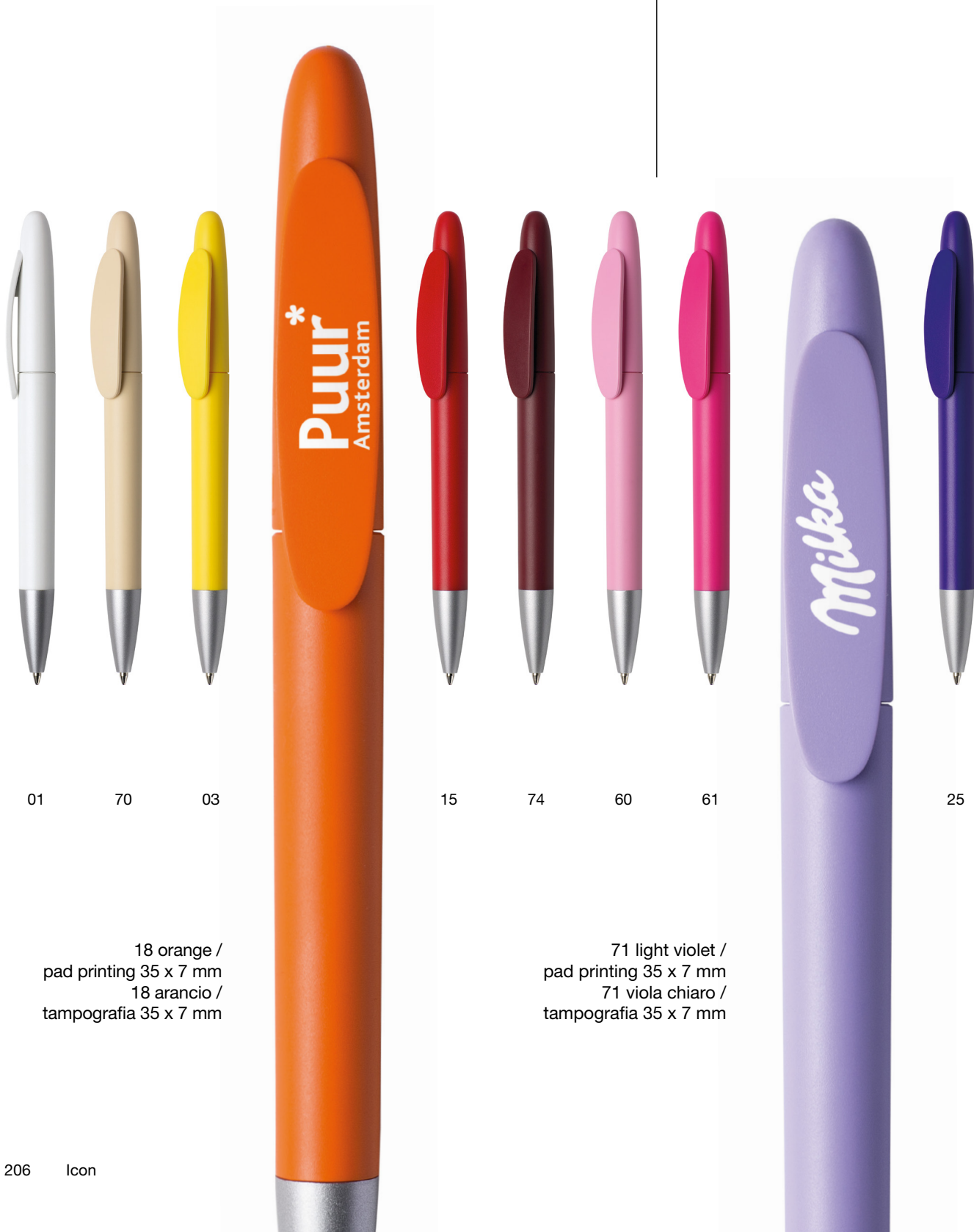

01

70

03

15

74

60

61

25

18 orange /
pad printing 35 x 7 mm
18 arancio /
tampografia 35 x 7 mm

71 light violet /
pad printing 35 x 7 mm
71 viola chiaro /
tampografia 35 x 7 mm

Colori coprenti con finitura satinata,
punta verniciata in colore alluminio



72

73

79

09

75

27 octan green / pad printing 35 x 7 mm
27 ottanio / tampografia 35 x 7 mm



64

12

22

04 black /
screen printing 40 x 30 mm
04 nero /
serigrafia 40 x 30 mm



IC400 | C CR

Solid colours with glossy finish,
chromed tip



01 white / pad printing 45 x 9 mm
01 bianco / tampografia 45 x 9 mm



70



03



18



15



74



60



61 magenta / pad printing 35 x 7 mm
61 magenta / tampografia 35 x 7 mm



71



25

Colori coprenti con finitura lucida,
punta cromata

73 brown / pad printing 35 x 7 mm
73 marrone / tampografia 35 x 7 mm



72



79

09



27

64

12

22

04

75 dark green / pad printing 35 x 7 mm
75 verde scuro / tampografia 35 x 7 mm

IC400 | 30 CR

Transparent colours with
glossy finish, chromed tip

*Colori trasparenti con finitura
lucida, punta cromata*



39



52



53



45 red / pad printing 35 x 7 mm
45 rosso / tampografia 35 x 7 mm



51



55



49



47 aquamarine /
pad printing 35 x 7 mm
47 acquamarina /
tampografia 35 x 7 mm



44



40

Transparent colours with
glossy finish, chromed tip

*Colori trasparenti con finitura
lucida, punta cromata*

IC400 | C GOLD

Solid colours with glossy finish,
gilded tip

*Colori coprenti con finitura lucida,
punta dorata*

04 black / screen printing 40 x 30 mm
04 nero / serigrafia 40 x 30 mm



01



74



75



22

IC400 | AL CR



Aluminium painted finish barrel
and cap, chromed tip

*Fusto e cappuccio verniciati in
colore alluminio, punta cromata*

aluminium / pad printing
35 x 7 mm
alluminio / tampografia
35 x 7 mm

Technical information
Informazioni tecniche

Icon

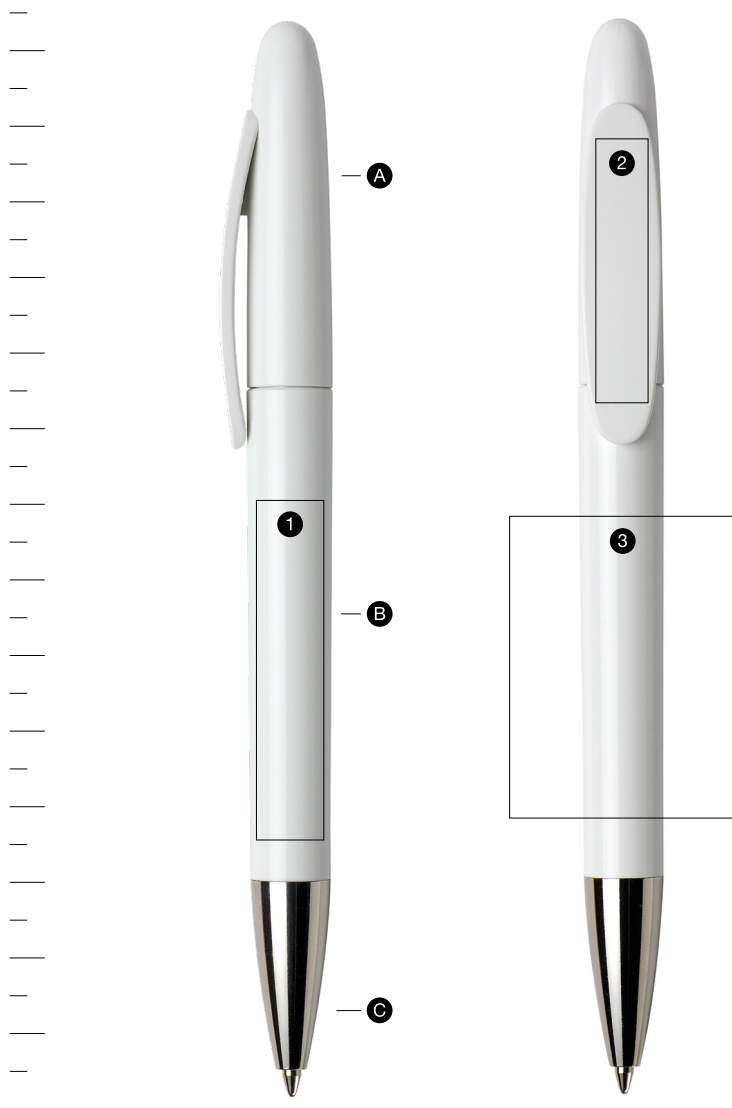

ø 11,3 mm
h 138,2 mm



The entire Maxema collection is available
in post-consumer recycled plastic on request /
*Tutta la collezione Maxema è realizzabile
in plastica riciclata post-consumo su richiesta*

Components / Componenti

- Ⓐ Cap / cappuccio
- Ⓑ Barrel / fusto
- Ⓒ Tip / punta

Print area / Area stampabile

- ① pad printing / tampografia
45 x 9 mm
- ② pad printing / tampografia
35 x 7 mm
- ③ screen printing / serigrafia
40 x 30 mm

Features / Caratteristiche

twist-action / meccanismo a rotazione

made of non-toxic, highly resistant
ABS plastic / realizzata in plastica ABS,
atossica e ad alta resistenza

galvanic process used to chrome and
gild ABS tip / la cromatura e la doratura
della punta in ABS sono ottenute
con trattamento galvanico

Jumbo refill, blue and black ink / refill
Jumbo, inchiostro blu e nero

available in glossy, matt and aluminium
painted finish / disponibile con superfici
lucide, satinare o alluminio

Fast Dry Gel blue and black ink available
on request /
*Refill Gel Fast Dry blu e nero disponibile
su richiesta*

Ethic



Elegance and flexibility.
Eleganza e flessibilità.

Tailored to the
customer's
requirements.

*Costruita a misura
di cliente.*



Technical information at p. 225
Informazioni tecniche a pag. 225

ET900 | MULTICOLOUR

Solid colours with glossy finish,
metal chrome finish clip, chromed tip

*Colori coprenti con finitura lucida,
clip in metallo cromato,
punta cromata*

Designed to
outlast passing
fashions, like
the message
it conveys



G green / pad printing 55 x 9,5 mm
G verde / tampografia 55 x 9,5 mm

Pensata per
durare oltre
le mode del
momento, come
il messaggio che
deve trasmettere

ET900 | FLAG

Solid colours with glossy finish, metal chrome finish clip, chromed tip

Colori coprenti con finitura lucida, clip in metallo cromato, punta cromata



FR

SP

GE

IT / pad printing 55 x 9,5 mm
IT / tampografia 55 x 9,5 mm

ET900 | C FLAG

Solid colours with glossy finish, metal chrome finish clip, chromed tip

Colori coprenti con finitura lucida, clip in metallo cromato, punta cromata



22 IT

04 IT / pad printing 55 x 9,5 mm
04 IT / tampografia 55 x 9,5 mm

ET900 | B

Solid colours with glossy finish, metal chrome finish clip, metal chrome tip

Colori coprenti con finitura lucida, clip in metallo cromato, punta cromata



03

18

15

74

25

09

12

22

04

03

15

74

25

09

12

22

18 orange /
pad printing
55 x 9,5 mm
18 arancio /
tampografia
55 x 9,5 mm

04 black /
pad printing
55 x 9,5 mm
04 nero /
tampografia
55 x 9,5 mm

PENTA BIOMEDICAL®

COENERGIA
group

ET900 | BC

Solid colours with glossy finish,
metal chrome finish clip, white top,
chromed tip and two rings

*Colori coprenti con finitura lucida,
clip in metallo cromato, due anelli
e punta cromati, tappino bianco*

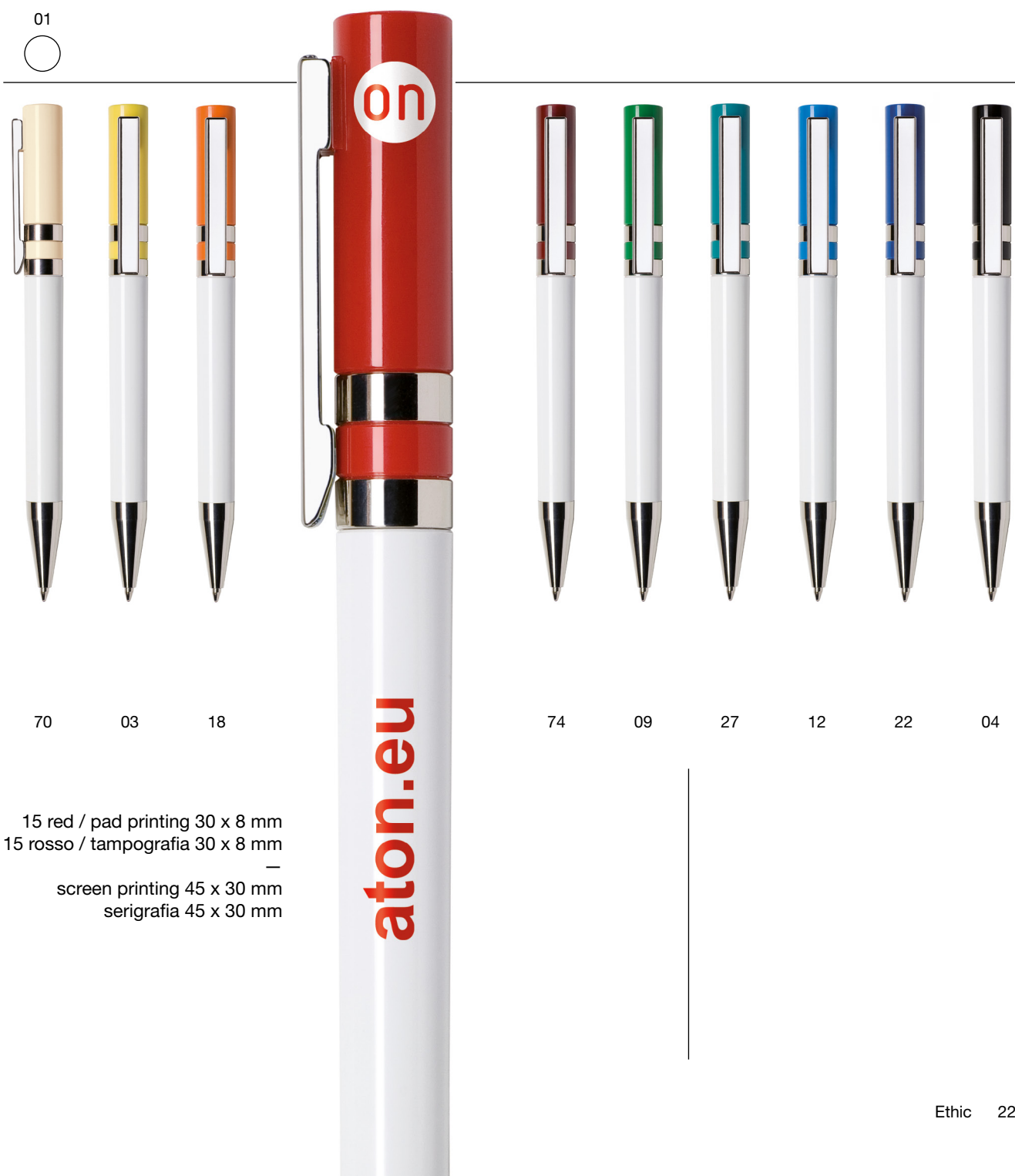

01

70

03

18

74

09

27

12

22

04

15 red / pad printing 30 x 8 mm
15 rosso / tampografia 30 x 8 mm

—
screen printing 45 x 30 mm
serigrafia 45 x 30 mm

ET900 | C CR

Solid colours with glossy finish, metal chrome finish clip, chromed tip, top and two rings

Colori coprenti con finitura lucida, clip in metallo cromato, due anelli, punta e tappino cromati

chrome



01

70

SAP FORUM | SUGMENA
CONFERENCE

18

15

03 yellow /
pad printing
55 x 9,5 mm
03 giallo /
tampografia
55 x 9,5 mm

25

09

75

27

ALFALUX

74 burgundy /
pad printing
55 x 9,5 mm
74 bordeaux /
tampografia
55 x 9,5 mm

ET900 | C GOLD

Solid colours with glossy finish, gilded metal finish clip, gilded tip, top and two rings

Colori coprenti con finitura lucida, clip in metallo dorato, due anelli, punta e tappino dorati

The chrome or gilded details enhance the pen's elegance.

chrome



12

22

04

gold



74

27

22

04

Gynefam[®]
ORO

01 white /
screen printing
45 x 30 mm
01 bianco /
serigrafia
45 x 30 mm

I dettagli,
cromati o dorati,
ne esaltano
l'eleganza.

Technical information
Informazioni tecniche

Ethic

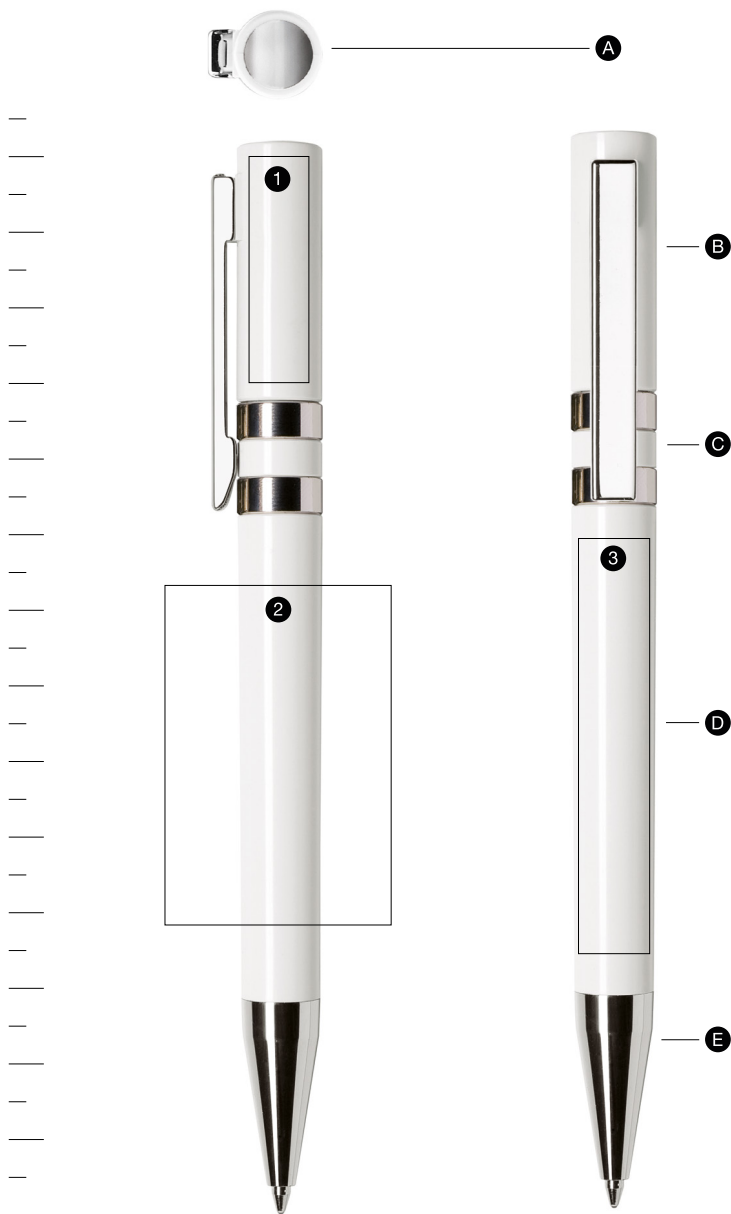

ø 11,2 mm
h 138,7 mm



The entire Maxema collection is available
in post-consumer recycled plastic on request /
*Tutta la collezione Maxema è realizzabile
in plastica riciclata post-consumo su richiesta*

Components / Componenti

- Ⓐ Small cap / tappino
- Ⓑ Cap / cappuccio
- Ⓒ Rings / anelli
- Ⓓ Barrel / fusto
- Ⓔ Tip / punta

Print area / Area stampabile

- ① pad printing / tampografia
30 x 8 mm
- ② screen printing / serigrafia
45 x 30 mm
- ③ pad printing / tampografia
55 x 9,5 mm

Features / Caratteristiche

twist-action / meccanismo a rotazione

made of non-toxic, highly resistant
ABS plastic / realizzata in plastica ABS,
atossica e ad alta resistenza

metal clip with chrome, or gilded finish /
clip in metallo, con finitura cromata o
dorata

galvanic process used to chrome
or to gild ABS parts / la cromatura e
la doratura delle parti in ABS sono
ottenute con trattamento galvanico

Jumbo refill, blue and black ink / refill
Jumbo, inchiostro blu e nero

available in glossy finish / disponibile
con superfici lucide

Fast Dry Gel blue and black ink available
on request /
*Refill Gel Fast Dry blu e nero disponibile
su richiesta*

Pixel



High resolution design.
Il design ad alta definizione.

A synthesis of
contemporary style.

*Sintesi dello stile
contemporaneo.*

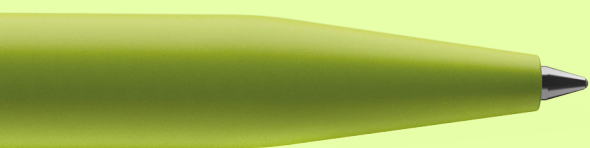

Also available in post-consumer recycled plastic /
Disponibile anche in plastica riciclata post-consumo



Also available in white antibacterial plastic /
Disponibile anche in plastica antibatterica bianca

Technical information at p. 249
Informazioni tecniche a pag. 249

PX40 | MATT CB

Solid colour barrel with matt finish, solid glossy white colour clip and push-button

Colours with matt finish and white clip: an easy, gritty combination.



70

03

18

15

74

60

71

25

73

61 magenta / pad printing 30 x 8 mm
61 magenta / tampografia 30 x 8 mm

Fusto in colore coprente con finitura satinata, clip e tappino in colore bianco coprente lucido

Colori con
finitura matt e
clip bianca: una
combinazione
facile e grintosa.



79

09

75

26

27

64

77

12

22

04

05 grey / pad printing 30 x 8 mm
05 grigio / tampografia 30 x 8 mm

PX40 | MATT

Solid colour barrel with matt finish, solid glossy colour clip and push-button

A pop and colourful pen, with an unmistakable style.



01

70

03

18

15

74

60

61

71

25

73

Fusto in colore coprente con finitura satinata, clip e tappino in colore coprente lucido

Una penna pop e colorata, dallo stile inconfondibile.

75 dark green / pad printing 30 x 8 mm
75 verde scuro / tampografia 30 x 8 mm



79

09

Sport LAND

26

27

64

77

12

22

ATMOSPHERA

04

05 grey / pad printing 30 x 8 mm
05 grigio / tampografia 30 x 8 mm

PX40 | MATT CR

Solid colour barrel with matt finish, solid glossy colour clip, chromed push-button



01

70



03 yellow /
pad printing
30 x 8 mm
03 giallo /
tampografia
30 x 8 mm



18



15



74



60



61



71



25

73 brown / pad printing 30 x 8 mm
73 marrone / tampografia 30 x 8 mm



Fusto in colore coprente con finitura satinata, clip in colore coprente lucido, tappino cromato



79

09

75

26 aquamarine /
pad printing
30 x 8 mm
26 acquamarina /
tampografia
30 x 8 mm



27



77



12



22



05



04

64 pastel blue / pad printing 60 x 9 mm
64 azzurro pastello / tampografia 60 x 9 mm

PX40 | B

Solid white colour barrel and push-button, solid colours clip, glossy finishes

Fusto e tappino in colore bianco coprente, clip in colori coprenti, finiture lucide



01 03 18 15



74 burgundy / pad printing 30 x 8 mm
74 bordeaux / tampografia 30 x 8 mm



09 12



22 blue /
pad printing
30 x 8 mm
22 blu /
tampografia
30 x 8 mm

PX40 | C

Solid colours with glossy finish

Colori coprenti con finitura lucida



70



03



18



15



09 green / pad printing 30 x 8 mm
09 verde / tampografia 30 x 8 mm



12



22

04 black / pad printing 30 x 8 mm
04 nero / tampografia 30 x 8 mm



PX40 | 30

Transparent colours
with glossy finish

*Colori trasparenti
con finitura lucida*

47 aquamarine /
pad printing
30 x 8 mm 47 ac-
quamarina /
tampografia
30 x 8 mm



39



52



53



45



51



55



49



44



40

PX40 | FROST NEUTRAL

Transparent colours, matt finish barrel,
glossy finish clip and push-button

*Colori trasparenti,
fusto con finitura satinata,
clip e tappino con finitura lucida*



53 orange /
pad printing
30 x 8 mm
53 arancio /
tampografia
30 x 8 mm

55 dark violet /
pad printing
30 x 8 mm
55 viola scuro /
tampografia
30 x 8 mm

52

45

51

49

47

44

40

PX40 | FROST

Transparent colours, matt finish barrel, glossy finish clip and push-button



39 52 53 45 59

41 magenta / pad printing 30 x 8 mm
41 magenta / tampografia 30 x 8 mm



31 lilac /
pad printing
30 x 8 mm
31 lilla /
tampografia
30 x 8 mm

51 55

*Colori trasparenti,
fusto con finitura satinata,
clip e tappino con finitura lucida*



37



38



49



34



67



44



40



50

78 lime / pad printing 30 x 8 mm
78 lime / tampografia 30 x 8 mm

PX40 | GOM C CR

Solid colour barrel with rubber finish,
solid colour clip with glossy finish,
chromed push-button

*Fusto in colore coprente gommato,
clip in colore coprente con finitura
lucida, tappino cromato*

15 red / pad printing 30 x 8 mm
15 rosso / tampografia 30 x 8 mm



18



74

61

25

79

09

22

04 black / pad printing 30 x 8 mm
04 nero / tampografia 30 x 8 mm



PX40 | GOM 30 CR

Solid colour barrel with rubber finish, transparent colour clip with glossy finish, chromed push-button

Fusto in colore coprente gommato, clip in colore trasparente con finitura lucida, tappino cromato

47 aquamarine / pad printing 30 x 8 mm
47 acquamarina / tampografia 30 x 8 mm



53

45



55

49



44

50

41 magenta /
pad printing
30 x 8 mm
41 magenta /
tampografia
30 x 8 mm





PX40 | MATT CB RE

Post-consumer recycled plastic
Solid colour barrel with matt finish,
solid glossy white colour clip
and push-button

Made of WEEE
(Waste of Electrical
and Electronic
Equipment)
recycled plastic.

PLASTIC POST-CONSUMER RECYCLED



10



76 desert / pad printing
30 x 8 mm
tampografia 30 x 8 mm



87

Extra customisation is available to
tell the story of this pen's origin.
Info at p. 277

*Disponibile una personalizzazione
extra per raccontare l'origine di
questa penna. Info a pag. 277*



*Plastica riciclata post-consumo
Fusto in colore coprente con finitura
satinata, clip e tappino in colore
bianco coprente con finitura lucida*

Realizzata in
plastica riciclata
da RAEE (Rifiuti di
Apparecchiature
Elettriche ed
Elettroniche).



19



21



07

58 graphite / pad printing 30 x 8 mm
tampografia 30 x 8 mm

**Download
Post-consumer
Recycled
Collection
Catalogue**

Scarica il catalogo
Post-consumer
Recycled
Collection





PX40 | MATT RE

RECYCLED PLASTIC POST-CONSUMER RECYCLED PLASTIC

06



10



76



87

Post-consumer recycled plastic
Solid colour barrel with matt finish,
solid glossy colour clip and push-button

Guaranteed
and certified
post-consumer
recycled plastic
of European origin.



Universal reclosable single pen case
in Fedrigoni recycled paper Ardesia.
Info at p. 288

*Astuccio universale richiudibile per
penna singola in cartoncino riciclato
Fedrigoni Ardesia.
Info pag. 288*



21



58



07

19 forest / pad printing 30 x 8 mm
tampografia 30 x 8 mm

*Plastica riciclata post-consumo
Fusto in colore coprente
con finitura satinata, clip e tappino
in colore coprente con finitura lucida*

Plastica riciclata
post-consumo
di provenienza
europea, garantita
e certificata.

**Download
Post-consumer
Recycled
Collection
Catalogue**

Scarica il catalogo
Post-consumer
Recycled
Collection



PX40 | MATT CB AB

Antibacterial plastic, solid white colour
barrel with matt finish, solid glossy
white clip and push-button

Safe, not just
in words.



01



solid / coprenti

01

white
bianco

Plastica antibatterica, fusto in colore bianco coprente con finitura satinata, clip e tappino in colore bianco coprente lucido

Sicura, non solo a parole.



Universal reclosable single pen case in Fedrigoni recycled paper Gesso. Info at p. 288

Astuccio universale richiudibile per penna singola in cartoncino riciclato Fedrigoni Gesso. Info pag. 288

**Download
Antibacterial
Pens
catalogue**

Scarica il
Catalogo
Antibacterial
Pens



Technical information
Informazioni tecniche

Pixel

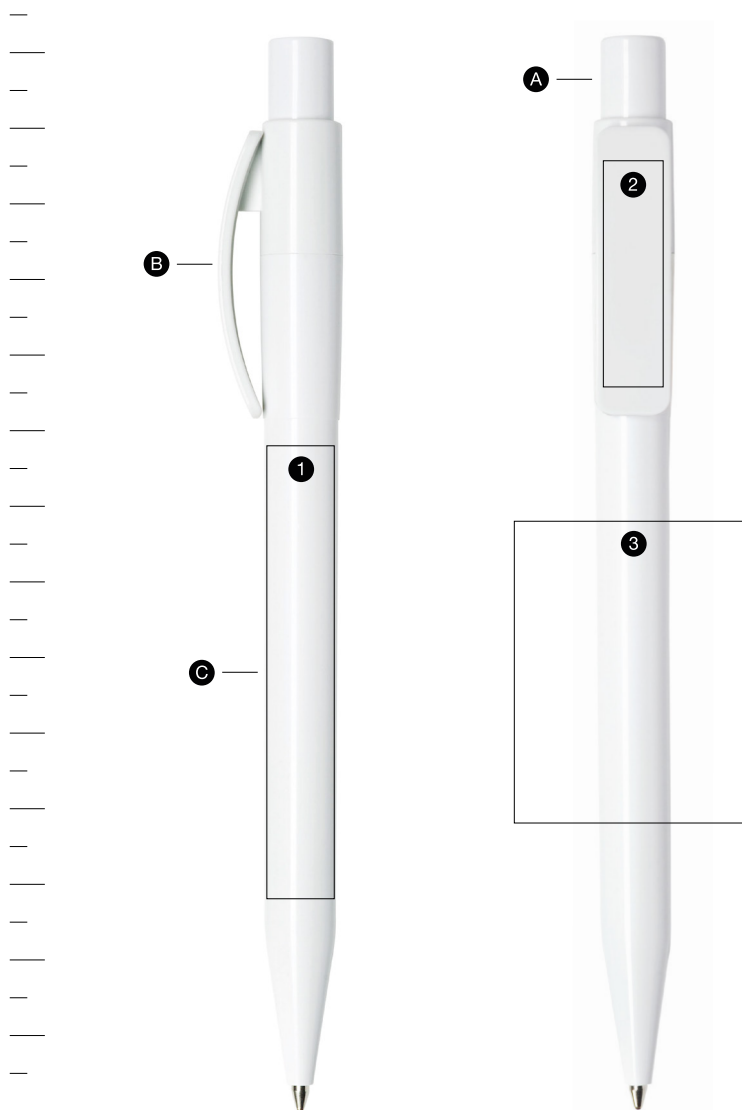

ø 10,2 mm
h 140 mm



POST-CONSUMER
RECYCLED PLASTIC

Pixel is available
in post-consumer recycled plastic/
*La penna Pixel è disponibile
in plastica riciclata post-consumo*

ANTIBACTERIAL
PLASTIC

Pixel is available
in white antibacterial plastic/
*La penna Pixel è disponibile
in plastica antibatterica bianca*

Components / Componenti

- Ⓐ Push-button / tappino
- Ⓑ Clip
- Ⓒ Barrel / fusto

Print area / Area stampabile

- ① pad printing / tampografia
60 x 9 mm
- ② pad printing / tampografia
30 x 8 mm
- ③ screen printing / serigrafia
40 x 31 mm

Features / Caratteristiche

retractable / meccanismo a scatto

ventilated push-button / tappino ventilato

made of non-toxic, highly resistant
ABS plastic / realizzata in plastica ABS,
atossica e ad alta resistenza

X-20 refill, blue and black ink /
refill X 20, inchiostro blu e nero

the barrel is available in glossy, matt
or rubberised finish / il fusto
è disponibile con superfici lucide,
satinare o gommate

galvanic process used to chrome
the ABS push-button / la cromatura
del tappino in ABS è ottenuta con
trattamento galvanico

 PX40 — POST-CONSUMER RECYCLED
PLASTIC/ PLASTICA RICICLATA POST-CONSUMO

Small imperfections and slight colour variations
are to be considered intrinsic features of
the recycled material deriving from the post-consumer
sector. / Piccole imperfezioni e lievi variazioni
cromatiche sono da considerarsi caratteristiche
intrinseche del materiale riciclato derivante dal post-
consumo.

Fast Dry Gel blue and black ink available
on request /
*Refill Gel Fast Dry blu e nero disponibile
su richiesta*

Bay



Casual and attractive
Disinvolta e accattivante

Draws attention
for its simplicity.

*Attrae per la
sua semplicità.*

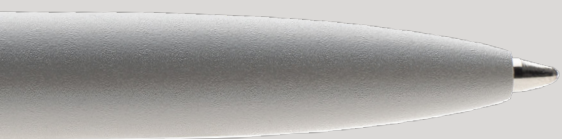

Also available in post-consumer recycled plastic /
Disponibile anche in plastica riciclata post-consumo



Also available in white antibacterial plastic /
Disponibile anche in plastica antibatterica bianca

Technical information at p. 265
Informazioni tecniche a pag. 265

B500 | MATT BC

Solid white colour barrel,
solid colours cap, matt finishes



70

03

18

15

74



61

71

25

73

79

60 pink / pad printing 30 x 7 mm
60 rosa / tampografia 30 x 7 mm

*Fusto in colore bianco coprente,
cappuccio in colori coprenti,
finiture satinare*



75 dark green / pad printing 30 x 7 mm
75 verde scuro / tampografia 30 x 7 mm
—
pad printing 60 x 7 mm
tampografia 60 x 7 mm



09



26

27

64

77

12

22

05



04 black / pad printing 60 x 7 mm
04 nero / tampografia 60 x 7 mm

B500 | MATT

Solid colours with matt finish

Effetto satinato:
raffinata
delicatezza
in 22 colori.

01 white / pad printing 30 x 7 mm
01 bianco / tampografia 30 x 7 mm



70

03

18

15

74

60

61

71

25

73 brown / pad printing 60 x 7 mm
73 marrone / tampografia 60 x 7 mm



Job til unge på kanten

High:five

Colori coprenti con finitura satinata

Delicately refined
matt finish in 22
colours.



79

09

75

26

64

77

12

22

05

04

27 octan green / pad printing 30 x 7 mm
27 ottanio / tampografia 30 x 7 mm

B500 | BC

Solid white colour barrel,
solid colours cap, glossy finishes

*Fusto in colore bianco coprente,
cappuccio in colori coprenti,
finiture lucide*



03



18



15



25



09



12



04

22 blue / pad printing 60 x 7 mm
22 blu / tampografia 60 x 7 mm

B500 | C

Solid colours with glossy finish

Colori coprenti con finitura lucida



01

70

03

18

15

74

09

12

22

04 black / pad printing 30 x 7 mm
04 nero / tampografia 30 x 7 mm





39



52



53



45 red /
pad printing
30 x 7 mm
45 rosso /
tampografia
30 x 7 mm



51



55



49



47 aquamarine /
pad printing
30 x 7 mm
47 acquamarina /
tampografia
30 x 7 mm



44



40

B500 | FROST

Transparent colours with matt finish
Colori trasparenti con finitura satinata

55 dark violet / pad printing 30 x 7 mm
55 viola scuro / tampografia 30 x 7 mm



39 neutral / pad printing 60 x 7 mm
39 neutro / tampografia 60 x 7 mm



B500 | MATT RE

RECYCLED PLASTIC POST-CONSUMER

Post-consumer recycled plastic
Solid colours with matt finishMade of WEEE
(Waste of Electrical
and Electronic
Equipment)
recycled plastic.

06



10



76



87

Universal single pen case
in Fedrigoni recycled paper
Ardesia. Info at p. 280Astuccio universale
per penna singola
in cartoncino riciclato
Fedrigoni Ardesia.
Info pag. 280



19



21



07

58 graphite / pad printing 30 x 7 mm
tampografia 30 x 7 mm

*Plastica riciclata post-consumo
Colori coprenti con finitura satinata*

Realizzata in
plastica riciclata
da RAEE (Rifiuti di
Apparecchiature
Elettriche ed
Elettroniche).

Extra customisation is available to
tell the story of this pen's origin.
Info at p. 276

*Disponibile una personalizzazione
extra per raccontare l'origine di
questa penna. Info a pag. 276*

**Download
Post-consumer
Recycled
Collection
Catalogue**

Scarica il catalogo
Post-consumer
Recycled
Collection



B500 | C AB

Antibacterial plastic, solid white colour with glossy finish

Protect your ideas,
one message
at a time.



01



solid / coprenti

01

white
bianco

*Plastica antibatterica, colore bianco
coprente con finitura lucida*

Proteggi
le tue idee,
un messaggio
alla volta.



Universal reclosable single pen case
in Fedrigoni recycled paper Gesso.
Info at p. 288

*Astuccio universale richiudibile per
penna singola in cartoncino riciclato
Fedrigoni Gesso.
Info pag. 288*

**Download
Antibacterial
Pens
catalogue**

Scarica il
Catalogo
Antibacterial
Pens



Technical information
Informazioni tecniche

Bay

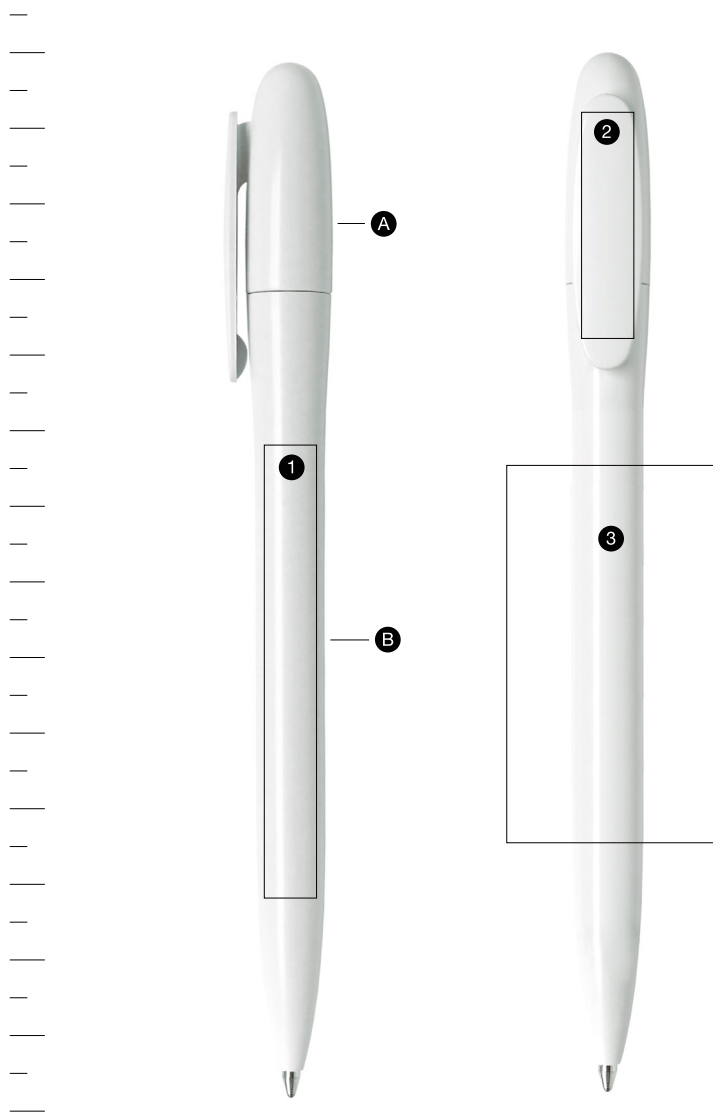

ø 10 mm
h 135 mm



Bay is available
in post-consumer recycled plastic/
*La penna Bay è disponibile
in plastica riciclata post-consumo*

ANTIBACTERIAL
PLASTIC

Bay is available
in white antibacterial plastic/
*La penna Bay è disponibile
in plastica antibatterica bianca*

Components / Componenti

- A** Cap / cappuccio
- B** Barrel / fusto

Print area / Area stampabile

- 1** pad printing / tampografia
60 x 7 mm
- 2** pad printing / tampografia
30 x 7 mm
- 3** screen printing / serigrafia
50 x 28 mm

Features / Caratteristiche

twist-action / meccanismo a rotazione

made of non-toxic, highly resistant
ABS plastic / realizzata in plastica ABS,
atossica e ad alta resistenza

X-20 refill, blue and black ink /
refill X-20, inchiostro blu e nero

available in glossy or matt finish /
disponibile con superfici lucide
o satinate

 B500 – POST-CONSUMER RECYCLED
PLASTIC/ PLASTICA RICICLATA POST-CONSUMO

Small imperfections and slight colour variations
are to be considered intrinsic features of
the recycled material deriving from the post-
consumer sector. / Piccole imperfezioni e lievi
variazioni cromatiche sono da considerarsi
caratteristiche intrinseche del materiale riciclato
derivante dal post-consumo.

Fast Dry Gel blue and black ink available
on request /
*Refill Gel Fast Dry blu e nero disponibile
su richiesta*



Scopri tutto quello che c'è da sapere per rendere ancora più speciale una penna Maxema.

More about Maxema

*Find out everything there is
to know to make a Maxema
pen even more special.*

Fast and reliable *Veloci e affidabili*

p. 270

Pen customisation *Personalizzazione penne*

p. 272

Cases *Astucci*

p. 280

Cases customisation *Personalizzazione astucci*

p. 290

Sample Sets *Campionari*

p. 292

Colour palette *Palette colori*

p. 304

Inks and refills *Inchiostri e refill*

p. 306

Fast and reliable

Veloci e affidabili

Speedy Delivery
Rapidità di consegna

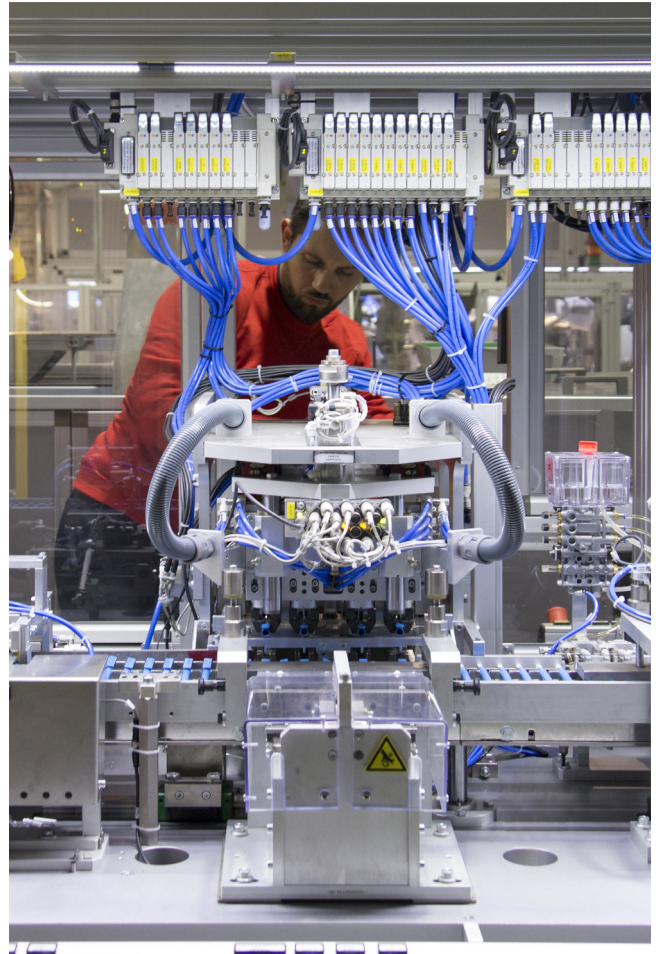

EN

The entire production process takes place at our plant where stringent quality controls are applied to test pen functionality and aesthetics. A team of specialists works on a daily basis to guarantee that every single pen meets our severe quality standards.

Large quantities of components are stored in our plant, ready for assembly by our highly automated machinery that is able to produce **from 2000 to 6000 pieces per hour**, guaranteeing speedy delivery times.

IT

L'intero processo produttivo si svolge all'interno del nostro stabilimento dove testiamo funzionalità ed estetica delle nostre penne con rigorosi controlli qualitativi. Un team di persone specializzate lavora ogni giorno per garantire che ogni singola penna risponda ai nostri severi standard di qualità.

Nel nostro stabilimento disponiamo di ingenti quantitativi di componenti e semi-lavorati pronti per essere assemblati da macchinari ad elevata automazione che assemblano **da 2.000 a 6.000 pezzi l'ora**: una garanzia di rapidità nei tempi di consegna.

Pens customisation

Personalizzazione penne

Printing techniques
Tecniche di stampa



EN

IT

Once assembled, the pen is ready to be customised with a logo, a QR Code or a message. Our Graphics Department will prepare digital simulations of possible alternatives and suggest new proposals to pinpoint the best result before going ahead with the printing.

Depending on logo features and what the pen is like, the Graphics Department gives its support and advice about what printing technique to use, including:

- ① Pad printing
- ② Screen printing
- ③ Laser engraving

Pad and screen printing are done using high-durability paints, while laser engraving allows you to customise even metal parts with elegance and precision. Once the print stage is completed the pens are put through strict quality controls. We can deliver printed pen samples on request. Contact our Sales Department for more information.

Una volta montata, la penna è pronta per essere personalizzata con un logo, un QR Code o un messaggio. Il nostro Studio Grafico elabora simulazioni digitali, propone alternative e suggerisce le soluzioni ottimali prima di procedere con la stampa.

In funzione delle caratteristiche del logo e della penna da personalizzare, lo Studio Grafico offre supporto e consulenza per individuare la migliore tecnica di stampa tra:

- ① Tampografia
- ② Serigrafia
- ③ Incisione laser

La tampografia e la serigrafia sono eseguite con uso di vernici ad alta tenuta, mentre l'incisione laser permette di personalizzare con eleganza e precisione anche le parti in metallo. Conclusa la fase di stampa, le penne sono sottoposte ad ulteriori e rigidi controlli qualitativi. Su richiesta realizziamo campioni stampati di singole penne. Contatta il nostro Ufficio Commerciale per maggiori informazioni.

Extra imprint (on demand) / Personalizzazione extra (su richiesta)

R-PET



1

Back / retro
IT

2

Back / retro
EN

The sustainability choice needs to be communicated.

So personalise your Kind with a message about this pen's origin.

-

Una scelta sostenibile va comunicata.

Personalizza la tua Kind con un messaggio che racconta l'identità di questa penna.

Sentence available in other languages on request.

-

Frase disponibile in altre lingue su richiesta.

Pad printing / tampografia

1 53 x 3 mm

2 60 x 3 mm

Extra imprint (on demand) / *Personalizzazione extra (su richiesta)*

PIR



①

Back / retro
EN

②

Back / retro
IT

Tell a story from the end.
Customise your Zed with a
message that also reveals
the origin of the pen.

-

*Racconta una storia
che comincia dalla fine.
Personalizza Zed con un
messaggio che descrive
l'origine di questa penna.*

Sentence available in other
languages on request.

-

*Frase disponibile in altre lingue
su richiesta.*

Pad printing / tampografia

① 53 x 3 mm

② 60 x 3 mm

Extra imprint (on demand)

POST-CONSUMER RECYCLED COLLECTION



**Icon Pure
Back**

Every pen has a story to tell, especially those made of post-consumer plastic. The customisation indicating the origin of the plastic used enhances the pen and the message it conveys.

You can customize with this sentence the models:

- **Icon Pure**
- **Flow Pure**
- **Dot**
- **Zink**
- **Pixel**
- **Bay**

Sentence available in other languages on request.
Frases disponibles en otras lenguas su riqhiesta.

Personalizzazione extra (su richiesta)

PENNE IN PLASTICA RICICLATA POST-CONSUMO



**Dot
Retro**

Ogni penna ha una storia da raccontare, soprattutto quelle prodotte in plastica post-consumo. La personalizzazione che indica la provenienza del materiale plastico con cui è realizzata valorizza la penna e il messaggio che porta con sé.

Puoi personalizzare con questa frase i modelli:

- **Icon Pure**
- **Flow Pure**
- **Dot**
- **Zink**
- **Pixel**
- **Bay**

Pad printing / tampografia

IT 46 x 3 mm

EN 40 x 3 mm

Mix&Match



To create an even more unique pen, **you can mix the colours and finishes available***.

-

*Per creare una penna ancora più unica e speciale **è possibile mixare i colori e le finiture disponibili.****

*Please contact our Sales Office for prices and minimum order quantities.
*Contatta l'Ufficio Commerciale per prezzi e quantitativi minimi.

Pantone Colours



Are 28 colours
not enough?
We can produce one or
more pen components
in a Pantone colour.*

-
*28 colori non bastano?
È possibile realizzare
una o più componenti
della penna in un colore
Pantone.**

*See the Price List for sales conditions
and minimum order quantities.
**Consulta il Listino Prezzi per condizioni
di vendita e quantitativi minimi.*

Cases

My Case Recycled



**Fedrigoni recycled paper Ardesia /
cartoncino riciclato Fedrigoni Ardesia**

The My Case pen box, suitable for all Maxema models, enhances the pen and highlights its message because it can be customised with pad or screen printing. The use of recycled cardboard makes it sustainable.

-
L'astuccio My Case, adatto a tutti i modelli Maxema, valorizza la penna e ne esalta il messaggio perché è personalizzabile in tampografia o serigrafia. In più è sostenibile, perché è in cartoncino riciclato.

More examples of customisation on p. 280
Altri esempi di personalizzazione a pag. 280



**Fedrigoni recycled paper Gesso /
cartoncino riciclato Fedrigoni Gesso**

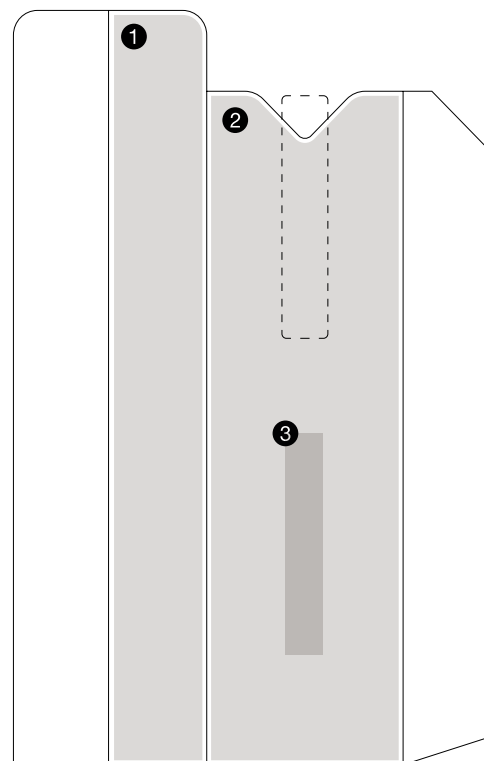

universal single pen case in Fedrigoni recycled paper Gesso and Ardesia 250 gr/m², FSC-certified, personalisable with pad and screen printing

size: 44 x 168 mm

—
astuccio universale per penna singola in cartoncino Fedrigoni riciclato Gesso e Ardesia 250 gr/m², certificato FSC, personalizzabile con stampa tampografica e serigrafica

dimensioni: 44 x 168 mm

Screen printing / serigrafia

- ❶ 21 x 166 mm
- ❷ 43 x 148 mm

Pad printing / tampografia

- ❸ 50 x 9 mm

My Case Kind

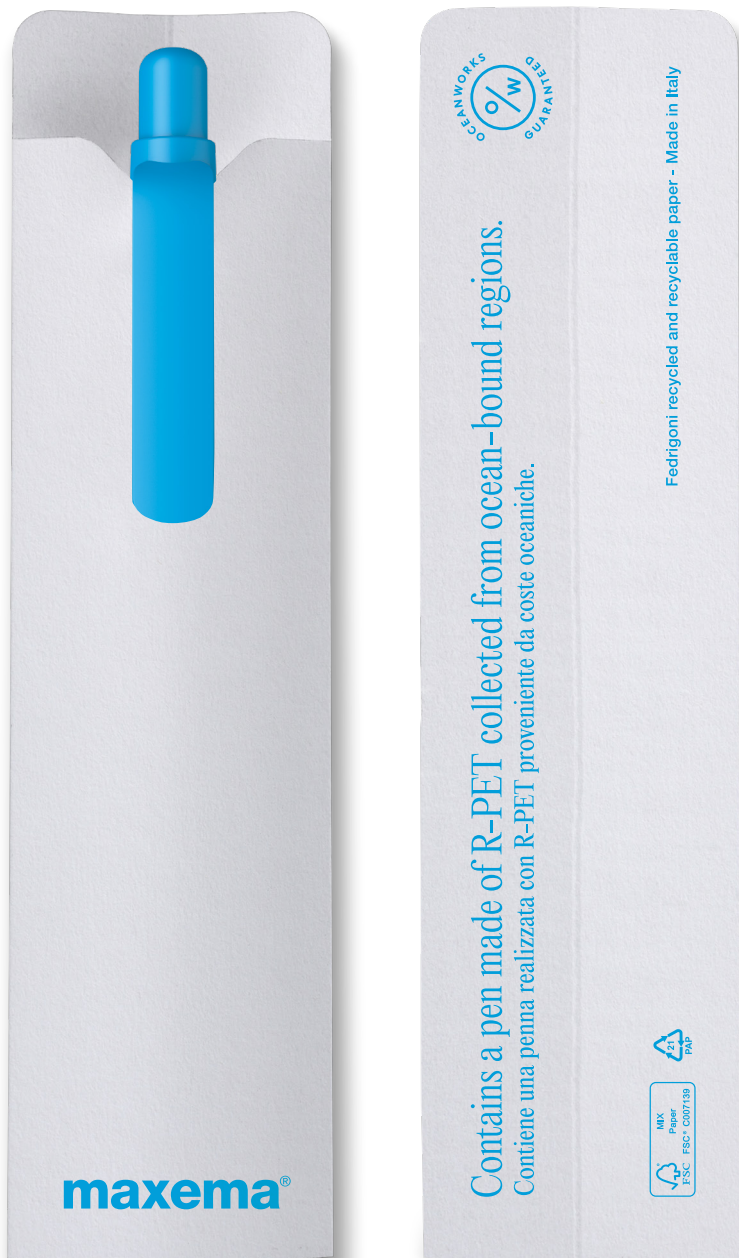

Fedrigoni recycled paper Gesso /
cartoncino riciclato Fedrigoni Gesso

The My Case box in recycled cardboard for the Kind model completes the presentation of the pen and tells the story of the origin of the material it is made of, amplifying the message of attention and kindness towards the environment.

-
L'astuccio in cartoncino riciclato My Case per il modello Kind accompagna la penna e racconta la provenienza del materiale con cui è realizzata, amplificando il messaggio di cura e gentilezza verso l'ambiente.



**Fedrigoni recycled paper Ardesia /
cartoncino riciclato Fedrigoni Ardesia**

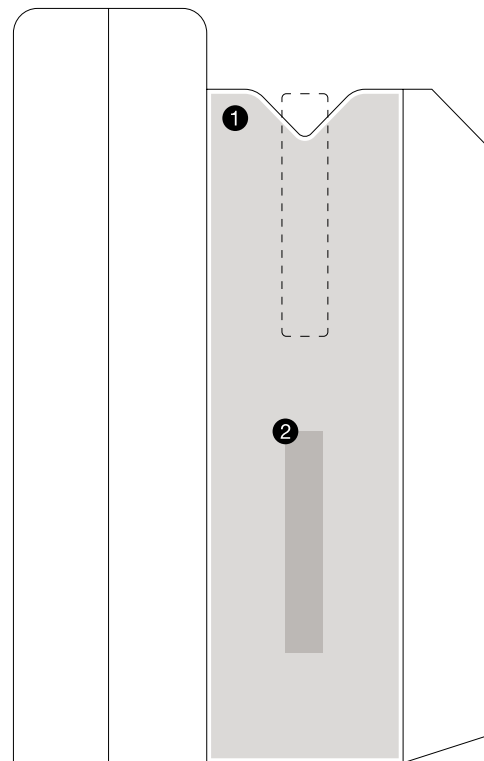

Kind single pen case in Fedrigoni recycled paper Gesso and Ardesia 250 gr/m², FSC-certified, personalisable with pad and screen printing

size: 44 x 168 mm

—
astuccio Kind per penna singola in cartoncino Fedrigoni riciclato Gesso e Ardesia 250 gr/m², certificato FSC, personalizzabile con stampa tampografica e serigrafica

dimensioni: 44 x 168 mm

Screen printing / serigrafia

❶ 42 x 148 mm

Pad printing / tampografia

❷ 50 x 9 mm

My Case Zed



A recycled paper case
for a story ready to
begin again

-
*Un astuccio in
carta riciclata, per
contenere una storia
pronta a ricominciare.*

**Fedrigoni recycled paper Materica Gesso /
cartoncino riciclato Fedrigoni Materica Gesso**



**Fedrigoni recycled paper Materica Ardesia /
cartoncino riciclato Fedrigoni Materica Ardesia**

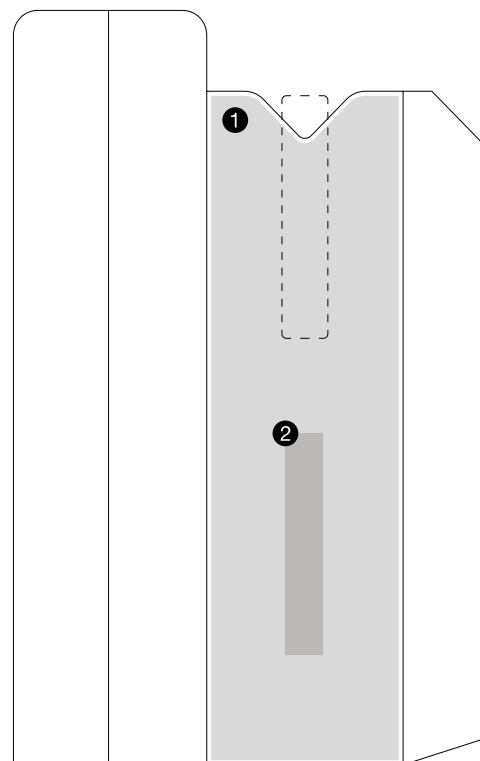

Zed single pen case in Fedrigoni recycled paper Materica Gesso and Ardesia 250 gr/m², FSC-certified, personalisable with pad and screen printing

size: 44 x 168 mm

—
astuccio Zed per penna singola in cartoncino Fedrigoni riciclato Gesso e Ardesia 250 gr/m², certificato FSC, personalizzabile con stampa tampografica e serigrafica

dimensioni: 44 x 168 mm

Screen printing / serigrafia

❶ 42 x 148 mm

Pad printing / tampografia

❷ 50 x 9 mm

My Case Post Consumer



**Fedrigoni recycled paper Materica Gesso /
cartoncino riciclato Fedrigoni Materica Gesso**

Made from recycled and certified paper, this case is not just packaging: it's an integral part of your sustainable message.

-
Realizzato in carta riciclata e certificata, questo astuccio non è solo una custodia: è parte integrante del tuo messaggio sostenibile.



**Fedrigoni recycled paper Materica Ardesia /
cartoncino riciclato Fedrigoni Materica Ardesia**

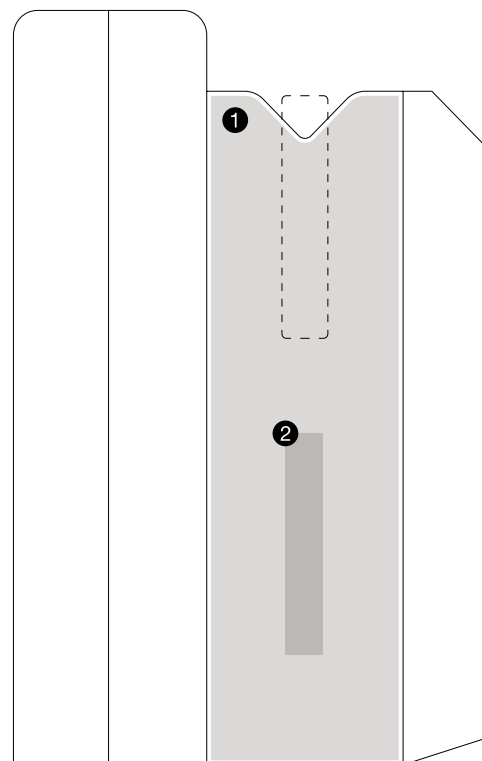

Single pen case in Fedrigoni recycled paper Materica Gesso and Ardesia 250 gr/m², FSC-certified, personalisable with pad and screen printing

size: 44 x 168 mm

—
Astuccio per penna singola in cartoncino Fedrigoni riciclato Gesso e Ardesia 250 gr/m², certificato FSC, personalizzabile con stampa tampografica e serigrafica

dimensioni: 44 x 168 mm

Screen printing / serigrafia

❶ 42 x 148 mm

Pad printing / tampografia

❷ 50 x 9 mm

My Box Recycled



**Fedrigoni recycled paper Gesso /
cartoncino riciclato Fedrigoni Gesso**

**Fedrigoni recycled paper Ardesia /
cartoncino riciclato Fedrigoni Ardesia**

I nostri astucci si prendono cura dell'ambiente.

Our cases look after the environment.

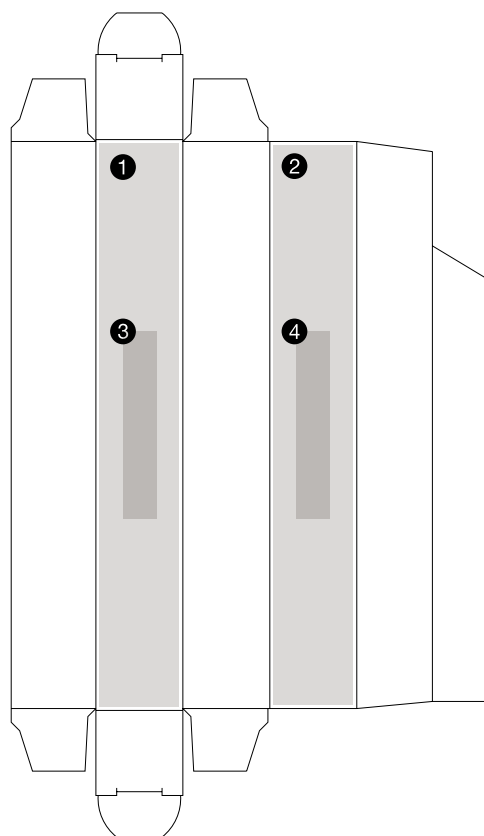

universal reclosable single pen case in Fedrigoni recycled paper Gesso and Ardesia 250 gr/m², FSC-certified, personalisable with pad and screen printing

size: 23 x 151 x 23 mm

—
astuccio universale richiudibile per penna singola in cartoncino Fedrigoni riciclato Gesso e Ardesia 250 gr/m², certificato FSC, personalizzabile con stampa tampografica e serigrafica

dimensioni: 23 x 151 x 23 mm

**Screen printing /
serigrafia**

① 148 x 20 mm

② 148 x 20 mm

**Pad printing /
tampografia**

③ 50 x 9 mm

④ 50 x 9 mm

More examples of customisation on p. 280
Altri esempi di personalizzazione a pag. 280

Cases customisation

Personalizzazione astucci



1



2



3



4

EN

Packaging can also be a communications medium. That's why our pen cases are made of environmentally-friendly materials and help tell the story of our and your care for the environment.

My Box and My Case are both customisable in two ways:

- **Standard** - with pad or screen printing
- **Custom** - with fully customised offset graphics

Contact our Sales Department for more information. In both events, each individual pen is inserted into its case and quality control is meticulous.

IT

Anche il packaging è uno strumento di comunicazione. Per questo i nostri astucci sono realizzati con materiali eco-friendly e contribuiscono a raccontare la nostra e la vostra attenzione verso l'ambiente.

My Box e My Case sono entrambi personalizzabili con due modalità:

- **Standard** – con stampa in tampografia o serigrafia
- **Custom** – con grafica interamente customizzata in offset

Contatta il nostro Ufficio Commerciale per richiedere maggiori informazioni. In entrambi i casi ogni singola penna viene inserita nel suo astuccio, con un meticoloso controllo qualità.

- 1 Pad printing / tampografia
- 2 Screen printing / serigrafia
- 3 Custom
- 4 Custom

Sample sets

Campionari

EN

Our Minikits and Sample Kits are designed to present all our models in the various finishes and colours available. You can also request samples of individual pens, either neutral or printed.

IT

I nostri Minikit e Kit di campionatura sono pensati per presentare tutti i nostri modelli, nelle diverse finiture e colori disponibili. È possibile richiedere anche campioni di singole penne, neutri o stampati.

Minikit

MOOD METAL



Metal elegance in 3 different finishes and clip available in 23 shades.

L'eleganza del metallo in 3 diverse finiture e clip disponibile in 23 colorazioni.



3 Mood Metal in chrome, titanium grey and gold finish

size: 10,2 x 19 cm (closed format)

3 Mood Metal nelle finiture: cromato, grigio titanio e oro

dimensioni: 10,2 x 19 cm (formato chiuso)

Minikit

8 PENS IN PIR PLASTIC



Contains 8 printed Zed pens in PIR ABS plastic, in assorted colours and logos.

size: 24,3 x 20 cm (closed format)

—
Contiene 8 penne Zed in plastica ABS PIR personalizzate con colori e loghi assortiti.

dimensioni: 24,3 x 20 cm (formato chiuso)

Minikit

8 R-PET PENS



Contains 8 printed KIND pens in R-PET plastic, in assorted colours and finishes.

size: 24,3 x 20 cm (closed format)

Contiene 8 penne KIND in plastica R-PET personalizzate, in colori e finiture assortite.

dimensioni: 24,3 x 20 cm (formato chiuso)

Minikit

8 POST-CONSUMER RECYCLED PENS



Care for our planet can also be expressed through the choice of sustainable packaging. An FSC-certified minikit made of cellulose, certified recycled fibres and cotton fibres. Respect for the environment and sustainability guaranteed by an effective display tool.

contains 8 pens of one model, in all available colours

size: 24,3 x 20 cm (closed format)

—
contiene 8 penne di un modello, in tutti i colori disponibili

dimensioni: 24,3 x 20 cm (formato chiuso)

Minikit

6 POST-CONSUMER RECYCLED PENS



L'attenzione verso il nostro pianeta si esprime anche attraverso la scelta di un packaging sostenibile. Un minikit certificato FSC composto da cellulosa, fibre di riciclo certificate e fibre di cotone. Rispetto dell'ambiente e sostenibilità garantite da un efficace strumento espositivo.



contains 6 different recycled plastic models:
Icon Pure, Flow Pure, Dot, Zink, Pixel and Bay

size: 19 x 19,8 cm (closed format)

contiene 6 diversi modelli di penne in plastica riciclata:
Icon Pure, Flow Pure, Dot, Zink, Pixel e Bay

dimensioni: 19 x 19,8 cm (formato chiuso)

Kit and box sets / Kit e raccoglitori

KIT

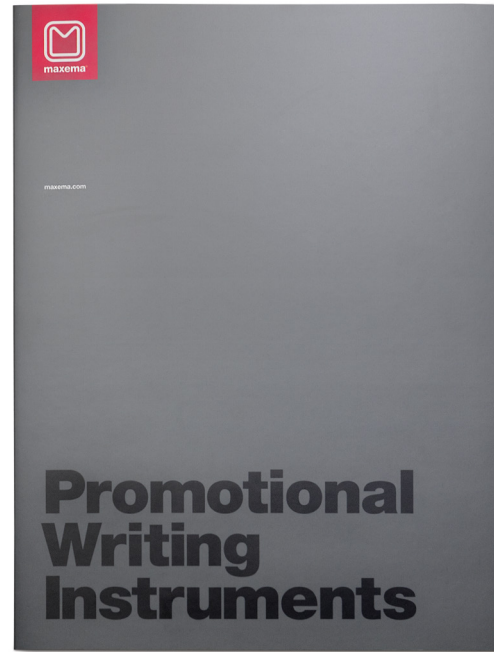

Maxema

Promotional Writing Instruments

Le nostre penne sono progettate e realizzate in Italia per durare a lungo nel tempo, non solo per massimizzare l'investimento del cliente, ma anche per evitare sprechi dannosi all'ambiente. Investire responsabilmente: è da sempre il nostro consiglio, anche quando si tratta di penne promozionali, meglio acquistarne meno, ma di eccellente qualità. La nostra è plastica ABS di prima scelta, atossica, con elevata resistenza a urti e calore, di eccellente lucentezza e stabilità di colore, priva

di sostanze pericolose come piombo, mercurio, cromo e cadmio (conforme a normative RoHS), una sicurezza per chi la utilizza e un sollievo per l'ambiente. La nostra verniciatura è a quattro strati di colori, per una perfetta tenuta e priva di sostanze tossiche. Riteniamo che il gesto d'ordine più importante per il nostro pianeta sia contenere la diffusione indiscriminata di prodotti inquinanti "usa e getta". Durabilità e ricerca spaziosa della qualità: questa è la nostra ricetta per la sostenibilità.

di eccellente stabilità di colore, priva

Inchiestri e refill / Inks and refills

X-20

Length: 107 mm, fits a 2000 mAh of cartridge
length: 107 mm, for up to 2000 metres of writing

Jumbo

Length: 107 mm, fits a 2000 mAh of cartridge
length: 107 mm, for up to 2000 metres of writing

RT 20 (on request / on demand)

fits in standard size (1.1 mm), Length: 98 mm, fits a 4000 mAh of cartridge
but standard size (1.1 mm), length: 98 mm, for up to 4000 metres of writing

RT 40 (on request / on demand)

fits in standard size (1.1 mm), Length: 98 mm, fits a 4000 mAh of cartridge
but standard size (1.1 mm), length: 98 mm, for up to 4000 metres of writing

Inchiestri / Inks

● Blue ● Black

● Blue ● Black

Il rubinetto del refill è in polipropilene, la punta è in ottone nichelato e la fibra in acciaio inox (1.1 mm). Caricamento: a richiesta.

The refill barrel is made of polypropylene, the tip is made of nickel-plated brass and the ball stainless steel (1.1 mm). The non-toxic ink is Documental.

Tutti gli inchiestri Documental sono conformi alle normative europee REACH e americana TSCA.

All Documental inks comply with European REACH and American TSCA standards.

"Produciamo penne in plastica, ma abbiamo a cuore l'ambiente."

Our pens are designed and manufactured in Italy to have a long life, not only to maximise investment returns for our customers, but also to minimise the quantity of waste material that is dispersed in the environment. Invest responsibly: this has always been our advice. Even in the case of promotional pens, it is better to purchase smaller quantities of superior quality products. We use 100% first-rate, virgin and non-toxic ABS plastic, highly resistant to knocks and to heat, guaranteeing excellent polish and

high colour stability, free from harmful substances such as lead, mercury, chrome and cadmium (conforms to RoHS standards), which makes our products safe for the users and friendly to the environment. Our painting: four layers of colour for a perfect use without toxic substances. We believe that the best way to put our concern for our planet to good use is to reduce the indiscriminate dissemination of "throw-away" products. Durability and all-out pursuit of quality: this is our sustainability programme.

We make plastic pens but we care about the environment.

Si richiede il possesso dell'ordine completo/verificandosi con penne di specifici modelli e colori. On request we can prepare customised sets of samples containing specific models and colours of pens.

20 printed pens in assorted colours of the most representative models

size: 25 x 34 cm (closed format)

20 penne stampate in colori assortiti dei modelli più rappresentativi

dimensioni: 25 x 34 cm (formato chiuso)

BOX SETS / RACCOGLITORI

The Kits are available in 1, 2 or 3 unit box sets /
i Kit sono disponibili in raccoglitori da 1, 2 o 3

- ❶ 28 x 33 x 3 cm
- ❷ 28 x 33 x 5,5 cm
- ❸ 28 x 33 x 8 cm

MODEL KIT / KIT MODELLO

20 printed pens in assorted colours of a single model
size: 25 x 34 cm (closed format)

—
*20 penne stampate in colori assortiti di un unico modello
dimensioni: 25 x 34 cm (formato chiuso)*

—
the Model Kit is available for / *il Kit Modello*
è disponibile per:
Zed, Kind, Icon Pure, Mood Metal, Dot Antibacterial,
Mood, Flow Pure, Flow, Dot, Zink, View, Tag, Icon, Icon
Green, Tag Green, Ethic, Pixel, Next, Bay.



On request we can prepare customised sets of samples
containing specific versions and colours of pens.

—
*Su richiesta possiamo realizzare campionari
personalizzati con penne di specifiche versioni e colori.*

Kit Dot Antibacterial

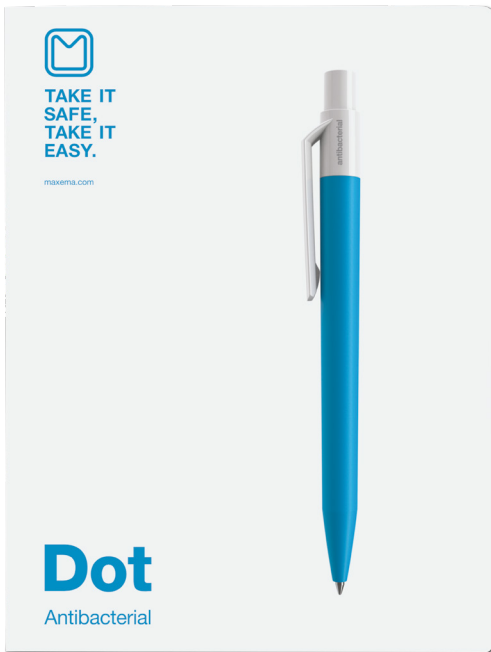

Dot Antibacterial

Take it safe, take it easy.

Anche quando scrivi, prendi cura di te: la plastica che usiamo per Dot Antibacterial impedisce ai batteri di depositarsi sulle superfici della penna e passare da una mano all'altra. Abbiamo bisogno di servizi protetti, ogni giorno e ogni ancora di più. Dot Antibacterial è la punta della collezione Maxema Antibacterial, sviluppata per unire design e sicurezza.

Take care of yourself even when you write: the plastic we use for Dot Antibacterial prevents bacteria from settling on pen surfaces and passing from one hand to the other. We need to feel protected, every day and today even more so. Dot Antibacterial is part of Maxema Antibacterial collection, able to combine design and safety.

La plastica, grazie a uno speciale additivo antimicrobico certificato ISO 22196:2011, rilascia ioni d'argento che distruggono fino al 99,99% dei batteri presenti sulla penna. In ufficio, al bar, nei luoghi pubblici, hai mai pensato a quanti microbo si orbitano attorno a quell'oggetto? Dot Antibacterial, abbinata a buona abitudine igieniche, garantisce un ulteriore livello di protezione.

Due to a special ISO 22196:2011 certified antimicrobial additive, the plastic releases silver ions that destroy up to 99,99% of the bacteria present on the pen. In the office, at the bar, in public places, has it ever crossed your mind how many microbes spread through the most everyday actions? Dot Antibacterial, combined with good hygiene habits, guarantees an additional level of protection.

informazioni tecniche / technical information

caratteristica	feature
microbatteria a metà, con molla di ritorno	middle of antibacterial ABS plastic with return spring
realizzata in plastica ABS antibatterica con speciale additivo antimicrobico certificato ISO 22196:2011	made of antibacterial ABS plastic with a special ISO 22196:2011 certified antimicrobial additive
inchiostro Jumbo 100, Blue and Black Ink	Jumbo 100, Blue and Black Ink
disponibile con apertura facile a spirale	available in glossy and matt finish
area stampabile	print area
① stampabile 60 x 9 mm	① full printing 60 x 9 mm
② stampabile 42 x 9 mm	② full printing 42 x 9 mm
③ stampabile 40 x 20 mm	③ custom printing 40 x 20 mm
compatibilità	compatibility
△ clip	△ clip
Ⓚ tappo	Ⓚ barrel
Ⓛ piccola elica	Ⓛ side spring

Perché scegliere / Why choose Maxema Antibacterial.

La plastica è antibatterica

Una speciale additivo antimicrobico certificato ISO 22196:2011, rilascia ioni d'argento a rilascio a lungo termine.

The plastic is antibacterial

A special ISO 22196:2011 certified antimicrobial additive releases silver ions gradually over time.

Batteri: fino al 99,99% in meno

Una speciale additivo antimicrobico certificato ISO 22196:2011, rilascia ioni d'argento a lungo termine.

Bacteria: up to 99,99% less

A special ISO 22196:2011 certified antimicrobial additive releases silver ions gradually over time.

Abbiamo a cuore la tua salute

Alcuni batteri possono causare malattie infettive, rendi la tua vita ancora più sicura, anche quando scrivi.

We care about your health

Some bacteria can cause disease and infections, make your life still safer, even when you write.

Contains 20 printed Dot antibacterial in assorted colours

size: 25 x 34 cm (closed format)

—
 Contiene 20 penne Dot in plastica antibatterica stampate in colori assortiti

dimensioni: 25 x 34 cm (formato chiuso)

Minikit Antibacterial

Monochromatic presentation of the Antibacterial collection: white has always been a symbol of safety and protection.

Presentazione monocromatica della collezione Antibacterial: il bianco è da sempre simbolo di sicurezza e protezione.



5 antibacterial printed pens in white colour

size: 10,2 x 19 cm (closed format)

—
5 penne antibacterial bianche

dimensioni: 10,2 x 19 cm (formato chiuso)

Minikit

GENERAL / GENERICO



The essential selection of our best sellers: Minikits are valuable tools to display, consult and collect.

La selezione essenziale dei nostri best seller: i Minikit sono strumenti preziosi da esporre, consultare, collezionare.



Maxema

Just a pen?

- Tutte le nostre penne sono ideate e realizzate interamente in Italia con materie prime italiane e tedesche di alta qualità.
- La nostra plastica ABS di prima scelta, atossica, con elevata resistenza ad urti e sbalzi termici, di eccellente lucentezza e stabilità di colore, priva di sostanze pericolose come piombo, mercurio, cromo e cadmio (conforme a normative RoHS).
- Il nostro inchiostro: solo Dokumental tedesco, atossico e conforme alle direttive europee REACH e americane (TSCA).
- I nostri nibbi: Jumbo con capacità di scrittura fino a 2500 nit e X-20 fino a 2000 nit.
- La nostra verniciatura: a quattro strati di colore, per una perfetta tenuta e prova di sostanze tossiche.
- Our pens are designed and produced entirely in Italy using only high quality Italian and German raw materials.
- Our plastic: top quality non-toxic ABS, highly resistant to knocks and sudden changes in temperature, of excellent glossiness and colour stability, free from dangerous substances such as lead, mercury, chrome and cadmium (conforms to RoHS standards).
- Our ink: only German, non-toxic Dokumental ink, conforms to European directives (REACH) and American (TSCA).
- Our nibs: Jumbo which can write for up to 2500 m and X-20 for up to 2000 m.
- Our painting: four layers of colour for a perfect seal and free from toxic substances.

palette colori / colour palette

coperti / solid			trasparenti / transparent		
01 bianco / white	02 crema / cream	03 giallo / yellow	04 neutro / neutral	05 giallo / yellow	06 arancio / orange
07 arancio / orange	08 rosso / red	09 bordeaux / burgundy	10 rosso / red	11 rosa / pink	12 magenta / magenta
13 arancio / orange	14 rosso / red	15 fucsia / fuchsia	16 viola / violet	17 viola / violet	18 viola scuro / dark violet
19 verde / green	20 verde scuro / dark green	21 verde scuro / dark green	22 verde / green	23 verde / green	24 verde / green
25 verde / green	26 verde / green	27 verde / green	28 verde / green	29 verde / green	30 verde / green
31 verde / green	32 verde / green	33 verde / green	34 verde / green	35 verde / green	36 verde / green
37 verde / green	38 verde / green	39 verde / green	40 verde / green	41 verde / green	42 verde / green
43 verde / green	44 verde / green	45 verde / green	46 verde / green	47 verde / green	48 verde / green
49 verde / green	50 verde / green	51 verde / green	52 verde / green	53 verde / green	54 verde / green
55 verde / green	56 verde / green	57 verde / green	58 verde / green	59 verde / green	60 verde / green
61 verde / green	62 verde / green	63 verde / green	64 verde / green	65 verde / green	66 verde / green
67 verde / green	68 verde / green	69 verde / green	70 verde / green	71 verde / green	72 verde / green
73 verde / green	74 verde / green	75 verde / green	76 verde / green	77 verde / green	78 verde / green
79 verde / green	80 verde / green	81 verde / green	82 verde / green	83 verde / green	84 verde / green
85 verde / green	86 verde / green	87 verde / green	88 verde / green	89 verde / green	90 verde / green
91 verde / green	92 verde / green	93 verde / green	94 verde / green	95 verde / green	96 verde / green
97 verde / green	98 verde / green	99 verde / green	100 verde / green	101 verde / green	102 verde / green
103 verde / green	104 verde / green	105 verde / green	106 verde / green	107 verde / green	108 verde / green
109 verde / green	110 verde / green	111 verde / green	112 verde / green	113 verde / green	114 verde / green
115 verde / green	116 verde / green	117 verde / green	118 verde / green	119 verde / green	120 verde / green
121 verde / green	122 verde / green	123 verde / green	124 verde / green	125 verde / green	126 verde / green
127 verde / green	128 verde / green	129 verde / green	130 verde / green	131 verde / green	132 verde / green
133 verde / green	134 verde / green	135 verde / green	136 verde / green	137 verde / green	138 verde / green
139 verde / green	140 verde / green	141 verde / green	142 verde / green	143 verde / green	144 verde / green
145 verde / green	146 verde / green	147 verde / green	148 verde / green	149 verde / green	150 verde / green
151 verde / green	152 verde / green	153 verde / green	154 verde / green	155 verde / green	156 verde / green
157 verde / green	158 verde / green	159 verde / green	160 verde / green	161 verde / green	162 verde / green
163 verde / green	164 verde / green	165 verde / green	166 verde / green	167 verde / green	168 verde / green
169 verde / green	170 verde / green	171 verde / green	172 verde / green	173 verde / green	174 verde / green
175 verde / green	176 verde / green	177 verde / green	178 verde / green	179 verde / green	180 verde / green
181 verde / green	182 verde / green	183 verde / green	184 verde / green	185 verde / green	186 verde / green
187 verde / green	188 verde / green	189 verde / green	190 verde / green	191 verde / green	192 verde / green
193 verde / green	194 verde / green	195 verde / green	196 verde / green	197 verde / green	198 verde / green
199 verde / green	200 verde / green	201 verde / green	202 verde / green	203 verde / green	204 verde / green
205 verde / green	206 verde / green	207 verde / green	208 verde / green	209 verde / green	210 verde / green
211 verde / green	212 verde / green	213 verde / green	214 verde / green	215 verde / green	216 verde / green
217 verde / green	218 verde / green	219 verde / green	220 verde / green	221 verde / green	222 verde / green
223 verde / green	224 verde / green	225 verde / green	226 verde / green	227 verde / green	228 verde / green
229 verde / green	230 verde / green	231 verde / green	232 verde / green	233 verde / green	234 verde / green
235 verde / green	236 verde / green	237 verde / green	238 verde / green	239 verde / green	240 verde / green
241 verde / green	242 verde / green	243 verde / green	244 verde / green	245 verde / green	246 verde / green
247 verde / green	248 verde / green	249 verde / green	250 verde / green	251 verde / green	252 verde / green
253 verde / green	254 verde / green	255 verde / green	256 verde / green	257 verde / green	258 verde / green
259 verde / green	260 verde / green	261 verde / green	262 verde / green	263 verde / green	264 verde / green
265 verde / green	266 verde / green	267 verde / green	268 verde / green	269 verde / green	270 verde / green
271 verde / green	272 verde / green	273 verde / green	274 verde / green	275 verde / green	276 verde / green
277 verde / green	278 verde / green	279 verde / green	280 verde / green	281 verde / green	282 verde / green
283 verde / green	284 verde / green	285 verde / green	286 verde / green	287 verde / green	288 verde / green
289 verde / green	290 verde / green	291 verde / green	292 verde / green	293 verde / green	294 verde / green
295 verde / green	296 verde / green	297 verde / green	298 verde / green	299 verde / green	300 verde / green

5 printed pens in assorted colours of the most representative models

size: 14,7 x 19 cm (closed format)

5 penne stampate in colori assortiti dei modelli più rappresentativi

dimensioni: 14,7 x 19 cm (formato chiuso)

POST-CONSUMER RECYCLED PLASTIC PENS / PENNE IN PLASTICA RICICLATA POST-CONSUMO – solid / coprenti

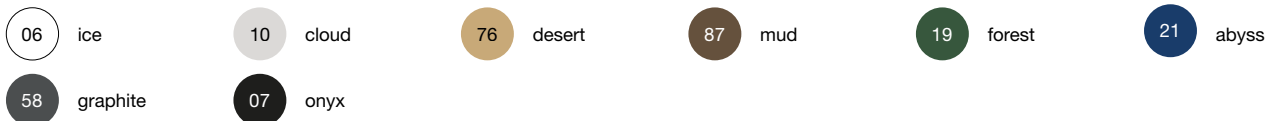

solid / coprenti



**(Available only for Zed model / disponibile solo per il modello Zed)*

transparent / trasparenti



**(Available only for Kind model / disponibile solo per il modello Kind)*

metallic paintings / vernici metallizzate



solid fluo / fluo coprenti

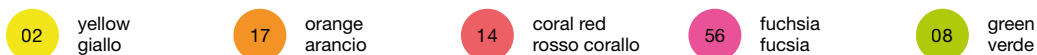

transparent fluo / fluo trasparenti



galvanic process / trattamento galvanico



metal finishes / finiture metallo



Our colour chart is shown below with the Pantone codes closest to those of our Palette. Matches are approximate.

In questa tabella sono riportati i nostri colori con i codici Pantone che più si avvicinano a quelli della nostra Palette. La corrispondenza è puramente indicativa.

solid / coprenti

01	white / bianco	
70	cream / crema	pant 7499
03	yellow / giallo	pant 120
18	orange / arancio	pant 1505
15	red / rosso	pant 187
74	burgundy / bordeaux	pant 195
60	pink / rosa	pant 1905
61	magenta	pant 213
71	light violet / viola chiaro	pant 270
25	dark violet / viola scuro	pant violet
72	leather / cuoio	pant 7571
73	brown / marrone	pant 7582
79	lime	pant 381
09	green / verde	pant 348
75	dark green / verde scuro	pant 3435
26	aquamarine / acquamarina	pant 3262
27	ocean green / ottanio	pant 321
64	pastel blue / azzurro pastello	pant 283
77	cyan / ciano	pant 2995
12	light blue / azzurro	pant 285
22	blue / blu	pant 288
05	grey / grigio	pant cool gray 4
04	black / nero	pant black 6
69	pastel green / verde pastello	pant 374 C
11	dark grey / grigio scuro	PMS 424 C
23	violet / viola	PMS 2602 C
16	bright red / rosso vivo	PMS 1795 C

trasparent / trasparenti

39	neutral / neutro	
52	yellow / giallo	pant 116
53	orange / arancio	pant 1505
45	red / rosso	pant 200
59	pink / rosa	pant 1905
41	magenta	pant 213
31	lilac / lilla	pant 2705
51	violet / viola	pant 2425
55	dark violet / viola scuro	pant violet
37	amber / ambra	pant 7571
38	brown / marrone	pant 7582
78	lime	pant 381
49	green / verde	pant 348
47	aquamarine / acquamarina	pant 3272
34	light blue / azzurro	pant 283
67	cyan / ciano	pant 306
44	blue / blu	pant 286
30	light grey / grigio chiaro	pant cool gray 6
40	grey / grigio	pant 437
32	pure grey / grigio puro	pant 431
50	dark grey / grigio scuro	pant 446

♻️ POST-CONSUMER RECYCLED PLASTIC PENS
PENNE IN PLASTICA RICICLATA POST-CONSUMO

solid / coprenti

06	ice	
10	cloud	pant cool gray 1 C
76	desert	pant 466 C
87	mud	pant 7532 C
19	forest	pant 7735 C
21	abyss	pant 654 C
58	graphite	pant 425 C
07	onyx	

Pantone colours are available on demand. Please contact us to find out the minimum order quantity for each model.
I colori Pantone sono disponibili su richiesta, contattateci per conoscere i quantitativi minimi per ogni modello.

Inks and refills / *Inchiostri e refill*

INKS / INCHIOSTRI



blue
blu



black
nero



red (upon request)
rosso (su richiesta)

X-20



aluminium tip, stainless steel ball Ø 1 mm, length 107 mm, for up to 2000 meters of writing

punta in alluminio, sfera in acciaio inossidabile, Ø 1 mm, lunghezza 107 mm, fino a 2000 metri di scrittura

JUMBO

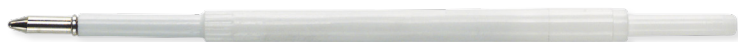

aluminium tip, stainless steel ball Ø 1 mm, length 107 mm,
for up to 2500 metres of writing

*punta in alluminio, sfera in acciaio inossidabile Ø 1 mm, tubetto in polipropilene,
lunghezza 107 mm, fino a 2500 metri di scrittura*

The ink is Dokumental.
All Dokumental inks comply
with European REACH and American
TSCA standards.

—
L'inchiostro, è Dokumental.
Tutti gli inchiostri Dokumental sono
conformi alla normativa europea REACH
e americana TSCA.

RT90 PARKER TYPE BLACK TUBE, BRANDED WITH MAXEMA LOGO ON DEMAND / RT90 TIPO PARKER TUBO NERO CON LOGO MAXEMA SU RICHIESTA



nickel-silver brass tip, tungsten carbide ball Ø 1 mm, polypropilene barrel,
length 98 mm, for up to 4000 metres of writing

*punta in ottone nichelato, sfera in carburo di tungsteno, Ø 1 mm,
tubetto in polipropilene, lunghezza 98 mm, fino a 4000 metri di scrittura*

The ink is Dokumental.
All Dokumental inks comply
with European REACH and American
TSCA standards.

—
L'inchiostro, è Dokumental.
Tutti gli inchiostri Dokumental sono
conformi alla normativa europea REACH
e americana TSCA.

RT90 PARKER TYPE TUBO BIANCO ON DEMAND RT90 TIPO PARKER TUBO BIANCO SU RICHIESTA



nickel-silver brass tip, tungsten carbide ball Ø 1 mm, polypropilene barrel,
length 98 mm, for up to 4000 metres of writing

*punta in ottone nichelato, sfera in carburo di tungsteno, Ø 1 mm,
tubetto in polipropilene, lunghezza 98 mm, fino a 4000 metri di scrittura*

GEL FAST DRY ON DEMAND / SU RICHIESTA



titanium carbide ball (SS, TC), Ø 0.7 mm, tip in stainless steel, length 98 mm,
up to 700 meters of writing

*sfera in carburo di titanio (SS, TC) Ø 0,7 mm, punta in acciaio inox,
lunghezza 98 mm, fino a 700 metri di scrittura*

Water-based, non-toxic gel ink,
produced in Italy and compliant with
European REACH and American TSCA
standards. The refill's barrel is made
of polypropilene.

—
**Inchiostro gel a base acqua, atossico
e prodotto in Italia, conforme alla
normativa europea REACH e americana
TSCA. Il tubetto del refill
è in polipropilene.**

all rights reserved maxema srl
tutti i diritti riservati maxema srl

The brands mentioned in this catalogue are the exclusive property of the respective owners. They are used for purely illustrative purposes and cannot be the object of any buying and selling transactions, under any circumstances.

I marchi menzionati in questo catalogo sono di proprietà esclusiva dei rispettivi proprietari. L'utilizzo dei suddetti marchi è a puro titolo esemplificativo e non potrà mai, in alcun caso, essere oggetto di trattative commerciali.

creative direction
undesign.it

still life
infinitostudio.com

editing
elena ambrosio
sara zampedri

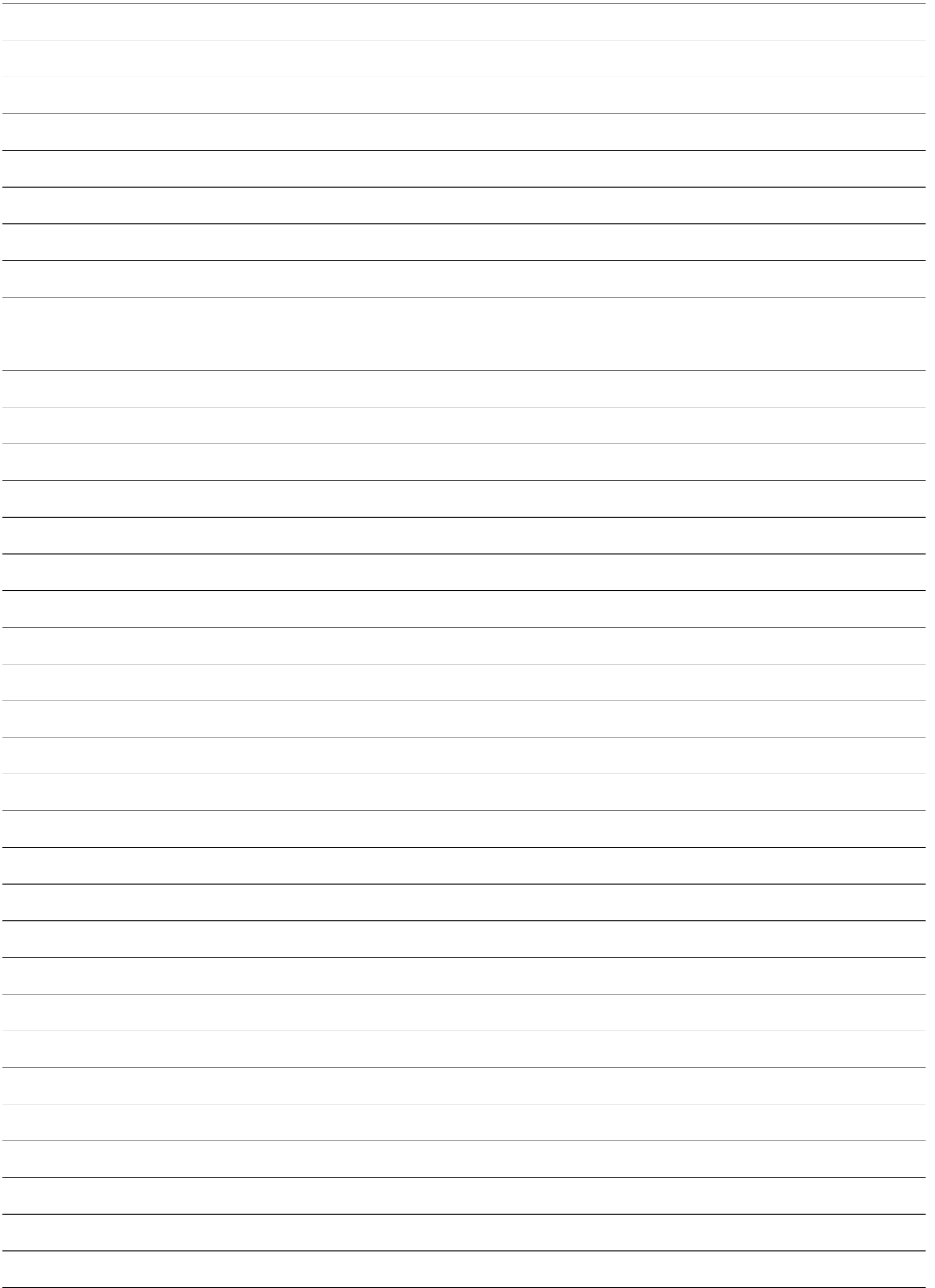



Printed in Italy on 100% recycled paper.
Stampato in Italia su carta 100% riciclata.



Made
in Italy



Prodotto
in Italia



Fabriqué
en Italie



Fabricado
en Italia

